

QUBO SERIES WORM GEARBOXES



rotomotive

Looks good. Performs better.





Rotomotive Powerdrives India Ltd is an Italian joint venture company operating in India since 2006. It has access to European technology and know-how from Motive srl, one of the joint venture partners and sources parts and components from Indian suppliers. We have a modern manufacturing facility in Gujarat, India. Rotomotive has the capacity to design, prototype and manufacture custom motors for various applications.

Our modern manufacturing plant has advanced machinery for automatic winding, trickle and vacuum pressure impregnation, precise balancing, conveyORIZED assembly, enclosed painting lines, automatic testing facilities with all components bar coded for traceability, consistent quality and low production time.

We also have an advanced testing facility for type testing motors and gearboxes which enables us to plot accurate speed torque curves and carry out temperature rise tests and other type tests as per IEC 60034/IS: 12615.

Our Manufacturing facility in India



Gearbox machining



Lean Assembly Line



Geared Motor Testing



Hardness Testing



Backlash Checking



Shop Floor



Our Manufacturing facility in Italy

INDEX

Technical characteristics	pag. 2-3
Efficiency Irreversibility	pag. 4
Mesh data	pag. 5
Lubrication	
Mounting Position	pag. 6
Technical data	pag. 7
Qubo Performance tables	pag. 8-9
Qubo Performance tables	pag. 10-11
Qubo Performance tables	pag. 12
Stadio	pag. 13
Qubo + Stadio	
Performance tables	pag. 14
Qubo + Stadio combinations	pag. 15
Qubo General data	pag. 16
Qubo Input and combinations	pag. 17
Output flange	pag. 18
Accessories	pag. 19
Components list	pag. 20



A



B



C



D



From QUBO 75 and up, 2 taper roller bearings are mounted on the wormshaft improving the mechanical resistance to the axial thrust generated by the wormwheel.

Moreover, the combination of this characteristic and 2 nilos (mounted on the QUBO sizes 75 to 150 keep lubrication grease inside the bearings even when they are not in contact with the oil bath), or, in alternative, special RS shields on such taper bearings, permits the mounting of the whole QUBO range from the size 30 to the size 150 in the positions V5 and V6 without any additional accessories.



The housing shape has been optimized to maximize the draining of water or liquid in the event of the gearbox being subjected to splashing or washing.

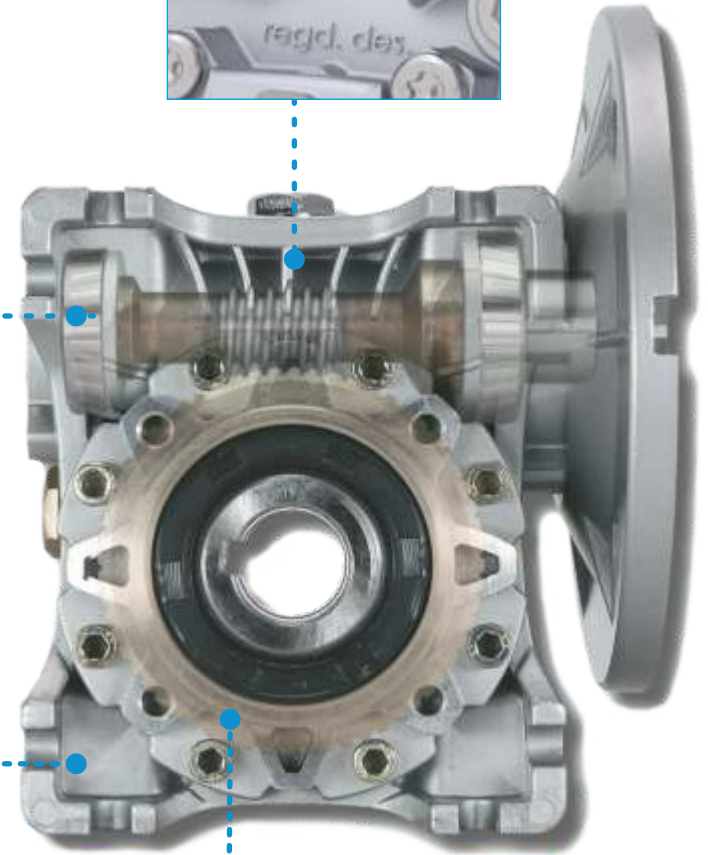

The new patented "QUBO" series of worm gear units is made with die cast aluminium housing from size 30 up to 90 and is cast iron for the size 110, 130 & 150.

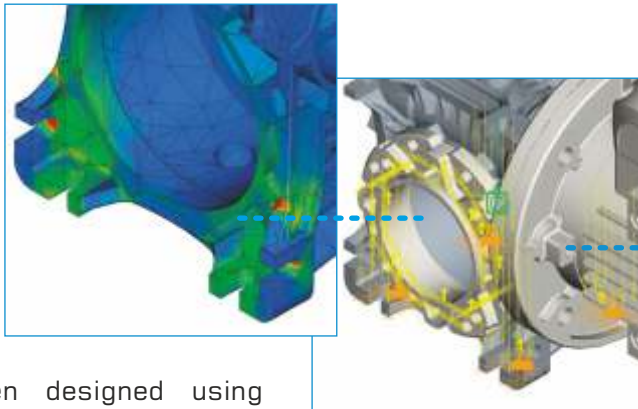

The housing has been designed using parametric 3D CAD software supported by systematic analysis of the thermal dissipation capacity and the structural resistance to deformation under the effect of working loads.

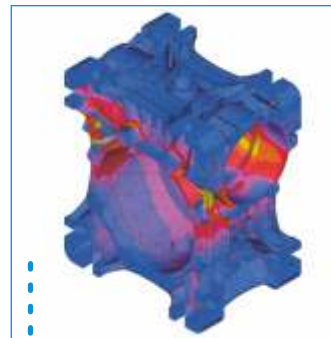

Mounting positions B6 or B7 are also permitted on all the QUBO series, thanks to the adoption of 2RS pre-lubricated bearings on the output gear.

In conclusion, the whole QUBO series can be mounted in any position with no need of specifications in the order.



QUBO units sizes 30 up to 90 are supplied with long life synthetic oil and they do not require any maintenance during their lifetime. QUBO size 110-150 uses mineral oil, but synthetic oil is available on request.

Each gearbox is supplied with a full set of filler, level and breather plugs, permitting all mounting positions.

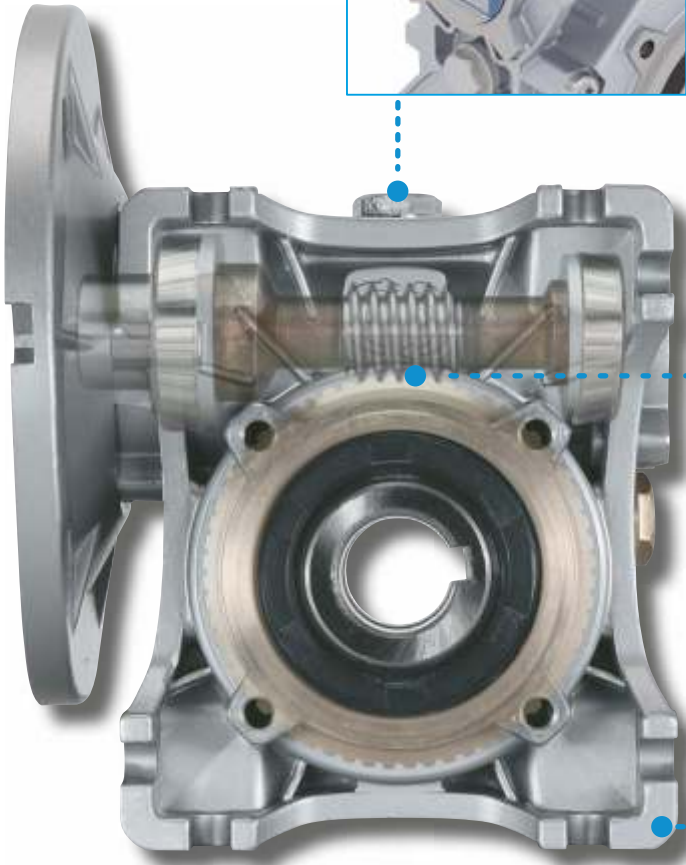

In order to reduce noise, improve efficiency and durability, the wormshaft is made of case hardened steel and profile ground, while the worm wheel is in shell cast ZCuSn12 bronze.

Before being assembled, the worm wheel is subjected to 'running in' working period to improve its surface finish and reduce noise.

A coat of paint seals minor surface porosities in aluminium and also protects the housing from oxidation.



Mating surface are machined for perfect perpendicularity.

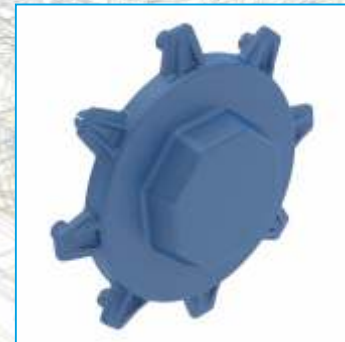

2 safety plastic covers on the output are always provided to protect QUBO during transportation and storage, and then the user from accidental contacts with moving parts.

An inherent factor in the selection of worm gear boxes is the efficiency η , defined as the ratio of mechanical power available at the output shaft and the power applied at the input shaft:

$$\eta = \frac{P_{n2}}{P_{n1}}$$

Some reasons concurring to a reduction of the efficiency can be identified in the several forms of silding and rolling friction.

In practice, efficiency depends on:

- helix angle
- materials of matching parts
- tooth form accuracy
- gear finishing
- lubrication
- gear sliding speed
- friction of seals and bearings
- load vibrations
- temperature

In the combined QUBO units (QUBO+QUBO) the total efficiency value is the product of the efficiency of the two single gear boxes composing the combined unit.

Dynamic efficiency η_d

It is the efficiency value achieved after completion of the running in time of few hours. This efficiency remains almost constant during the operating life of the gearbox.

The graph 1 shows the time required to reach the maximum value of dynamic efficiency

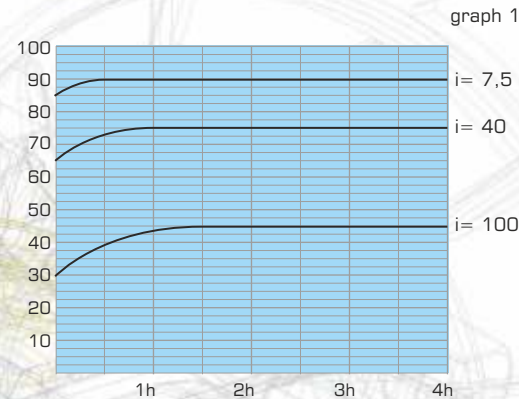

Static efficiency η_s

It is the efficiency obtained at start-up and is particularly important in the choice of a QUBO unit on intermittent duty applications (like lifts, hoists) where due to very short operating time, the standard operating conditions are seldom reached. In such applications, the motor rating is to be suitably increased to compensate for the poor efficiency of the QUBO unit while starting up ($\eta_s < \eta_d$)

Some QUBO units permit the locking and holding in place the load and prevent reverse motion even when electric power is switched off.

This feature called irreversibility is inversely proportional to the efficiency and the helix angle and directly proportional to the reduction ratio.

The profile of gear teeth and the helix angle of gears has the most significant bearing on the overall efficiency of the gearbox.

In order to achieve the optimum solution for any application it is necessary to analyze the difference between static and dynamic irreversibility.

Static irreversibility:

A QUBO unit has a low static reversibility when it is possible to rotate it only by driving the output shaft with a very high torque and / or vibration or twisting of the output load. The static irreversibility is inversely proportional to the static efficiency. Theoretically:

$\eta_s < 50\%$	static irreversibility
$50\% < \eta_s < 55\%$	low static reversibility
$\eta_s \geq 55\%$	good static reversibility

Dynamic irreversibility:

This is the most difficult condition to achieve. It occurs when the output shaft stops rotating as soon as the input shaft stops rotating. The dynamic irreversibility is inversely proportional to the dynamic efficiency. Theoretically:

$\eta_s < 40\%$	total dynamic irreversibility
$40\% < \eta_s < 50\%$	good dynamic irreversibility
$50\% < \eta_s < 60\%$	low dynamic reversibility
$\eta_s \geq 60\%$	good dynamic reversibility

The table 1 states an indicative condition of the different degrees of irreversibility based on the helix angle.

(Note: Whenever a total irreversibility of a QUBO unit is important for safety reasons, we strongly recommend the use of brake motors of the series Delphi ATAC or ATDC.)

MESH DATA

type	Ratio i:	7.5	10	15	20	25	30	40	50	60	80	100
QUBO 030	Z ₁	4	3	2	2	2	1	1	1	1	1	1
	Z ₂	30	30	30	40	50	30	40	50	60	80	
	β	18° 48' 58"	14° 20' 8"	9° 40' 7"	7° 42' 13"	5° 42' 38"	4° 52' 9"	3° 52' 10"	3° 15' 37"	2° 13' 37"	2° 6' 36"	
	m _x	1.44	1.44	1.44	1.10	1.75	1.44	1.10	0.90	0.70	0.56	
	Cr(Nm)	84.41Nm	82.46Nm	81.05Nm	67.95Nm	226.03Nm	80.18Nm	67.49Nm	59.58Nm	44.59Nm	46.39Nm	
	η _d (1400)	82.00%	80.70%	72.60%	72.00%	68.00%	62.00%	55.00%	52.00%	46.00%	40.00%	
	η _s	65.42%	62.00%	51.86%	47.33%	39.27%	34.68%	31.74%	25.65%	25.89%	19.60%	
QUBO 040	Z ₁	4	3	2	2	2	1	1	1	1	1	1
	Z ₂	30	30	30	40	50	30	40	50	60	80	100
	β	24° 28' 25"	18° 50' 51"	12° 49' 17"	10° 29' 51"	8° 45' 5"	6° 29' 31"	5° 17' 36"	4° 24' 5"	3° 47' 4"	2° 56' 9"	2° 28' 53"
	m _x	2	1.5	2	1.5	2.5	2	1.5	1.25	1	0.75	0.65
	Cr(Nm)	198.24Nm	107.24Nm	185.05Nm	128.51Nm	464.41Nm	181.60Nm	126.90Nm	115.09Nm	91.13Nm	59.48Nm	56.58Nm
	η _d (1400)	87.30%	85.30%	81.00%	78.00%	75.00%	69.70%	65.00%	62.00%	56.00%	50.00%	49.0%
	η _s	71.24%	67.24%	59.27%	53.87%	50.18%	44.81%	38.77%	35.07%	29.90%	25.95%	24.77%
QUBO 050	Z ₁	4	3	2	2	2	1	1	1	1	1	1
	Z ₂	30	30	30	40	50	30	40	50	60	80	100
	β	23° 57' 45"	18° 26' 6"	12° 31' 43"	10° 18' 17"	8° 35' 51"	6° 20' 25"	5° 11' 40"	4° 24' 5"	3° 41' 53"	2° 51' 45"	2° 17' 26"
	m _x	2.50	2	2.50	2.00	1.5	2.50	2.00	1.5	1.25	1.00	0.75
	Cr(Nm)	352.59Nm	217.36Nm	330.06Nm	285.40Nm	208.90Nm	324.18Nm	281.96Nm	207.16Nm	166.11Nm	148.02Nm	105.45Nm
	η _d (1400)	89.00%	87.50%	81.80%	80.20%	75.20%	70.60%	68.30%	61.30%	57.90%	52.80%	46.00%
	η _s	70.80%	67.15%	58.86%	55.84%	50.46%	43.14%	39.76%	34.06%	31.40%	26.90%	21.12%
QUBO 063	Z ₁	4	3	2	2	2	1	1	1	1	1	1
	Z ₂	30	30	30	40	50	30	40	50	60	80	100
	β	25° 50' 36"	19° 57' 51"	13° 36' 49"	10° 53' 8"	8° 44' 46"	6° 30' 20"	5° 29' 32"	4° 23' 55"	3° 56' 43"	3° 5' 17"	2° 26' 1"
	m _x	3.0	2.5	3.0	2.50	2.00	3.0	2.50	2.0	1.75	1.25	1.0
	Cr(Nm)	644.41Nm	428.50Nm	596.72Nm	595.72Nm	495.36Nm	583.72Nm	587.70Nm	491.04Nm	395.47Nm	280.91Nm	227.67Nm
	η _d (1400)	89.10%	88.60%	82.40%	81.80%	79.70%	73.00%	70.60%	67.50%	64.50%	57.90%	51.10%
	η _s	71.89%	68.23%	59.57%	55.54%	52.11%	43.97%	40.34%	36.82%	34.33%	28.44%	24.05%
QUBO 075	Z ₁	4	3	2	2	2	1	1	1	1	1	1
	Z ₂	30	30	30	40	50	30	40	50	60	80	100
	β	26° 38' 16"	20° 36' 57"	14° 4' 5"	11° 18' 36"	10° 18' 18"	7° 8' 51"	5° 42' 38"	5° 11' 40"	4° 20' 31"	3° 24' 42"	2° 51' 45"
	m _x	4.0	3.0	3.75	3.00	2.50	3.75	3.00	2.5	2.0	1.5	1.25
	Cr(Nm)	1268.82Nm	681.60Nm	1027.63Nm	859.08Nm	777.54Nm	1004.61Nm	846.60Nm	768.15Nm	516.79Nm	404.64Nm	355.85Nm
	η _d (1400)	91.00%	89.60%	85.20%	83.50%	81.90%	75.80%	73.80%	70.70%	65.50%	59.00%	56.50%
	η _s	72.60%	69.24%	61.14%	58.04%	54.26%	45.88%	43.05%	38.94%	35.27%	28.52%	26.71%
QUBO 090	Z ₁	4	3	2	2	2	1	1	1	1	1	1
	Z ₂	30	30	30	40	50	30	40	50	60	80	100
	β	29° 11' 11"	22° 43' 48"	15° 36' 15"	13° 1' 15"	11° 18' 36"	7° 56' 58"	6° 35' 44"	5° 42' 38"	4° 45' 49"	3° 52' 55"	3° 7' 20"
	m _x	4.5	3.5	5.0	3.5	3.00	5	3.5	3.00	2.50	1.75	1.50
	Cr(Nm)	2017.81Nm	1155.1Nm	2258.08Nm	1412.23Nm	1235.76Nm	2195.95Nm	1385.09Nm	1217.80Nm	1045.59Nm	648.29Nm	603.00Nm
	η _d (1400)	91.30%	89.90%	88.20%	84.10%	83.50%	80.80%	74.00%	73.10%	69.60%	61.40%	59.00%
	η _s	74.05%	70.71%	65.64%	60.07%	57.02%	50.76%	44.40%	41.63%	38.33%	31.19%	28.00%
QUBO 110	Z ₁	4	3	2	2	2	1	1	1	1	1	1
	Z ₂	30	30	30	40	50	30	40	50	60	80	100
	β	28° 14' 32"	21° 56' 32"	15° 1' 59"	14° 48' 14"	12° 59' 41"	7° 38' 54"	7° 31' 39"	6° 34' 55"	5° 48' 8"	4° 27' 28"	3° 52' 55"
	m _x	6	4.5	6.0	4.5	3.5	6.0	4.5	3.5	3.0	2.25	1.85
	Cr(Nm)	4344.98Nm	2321.25Nm	3963.38Nm	2646.64Nm	1846.57Nm	3862.09Nm	2581.03Nm	1811.22Nm	1645.28Nm	1179.69Nm	1101.56Nm
	η _d (1400)	92.40%	91.20%	88.40%	86.10%	83.80%	81.00%	77.20%	73.50%	72.00%	66.00%	63.00%
	η _s	73.92%	70.71%	64.76%	62.80%	58.86%	49.22%	47.51%	43.12%	40.20%	34.93%	31.80%
QUBO 130	Z ₁	4	3	2	2	2	1	1	1	1	1	1
	Z ₂	30	30	30	40	50	30	40	50	60	80	100
	β	29° 14' 56"	22° 46' 57"	15° 38' 32"	13° 47' 27"	11° 53' 34"	7° 58' 11"	6° 59' 48"	6° 0' 40"	5° 16' 6"	4° 23' 55"	3° 34' 35"
	m _x	7	7	7	5.4	4.37	7	5.4	4.37	3.67	2.75	2.75
	Cr(Nm)	6876.02Nm	6507.03Nm	6230.10Nm	4496.63Nm	3583.10Nm	6057.87Nm	4399.77Nm	3525.58Nm	2870.01Nm	1922.30Nm	2433.21Nm
	η _d (1400)	90.00%	86.00%	84.00%	83.00%	81.00%	79.00%	75.00%	72.00%	70.00%	65.00%	62.00%
	η _s	72.00%	66.67%	61.53%	60.54%	56.89%	48.00%	46.15%	42.24%	39.09%	34.40%	31.29%
QUBO 150	Z ₁	6	4	3	2	2	2	1	1	1	1	1
	Z ₂	45	40	45	40	50	60	40	50	60	80	100
	β	32° 54' 19"	25° 29' 51"	17° 55' 41"	13° 24' 45"	11° 18' 36"	9° 55' 34"	6° 47' 58"	5° 42' 38"	5° 0' 2"	4° 9' 35"	3° 37' 43"
	m _x	5.5	6.2	5.5	6.2	5	4.2	4.2	5	4.2	3.2	2.6
	Cr(Nm)	4411.41Nm	5214.29Nm	3892.70Nm	7027.85Nm	5617.08Nm	1961.79Nm	6884.59Nm	5535.47Nm	4562.35Nm	3469.44Nm	2900.18Nm
	η _d (1400)	90.00%	86.00%	84.00%	83.00%	81.00%	79.00%	75.00%	72.00%	70.00%	65.00%	62.00%
	η _s	72.00%	66.67%	61.53%	60.54%	56.89%	48.00%	46.15%	42.24%	39.09%	34.40%	31.29%

tab. 1

Z₁ nr of starts of the worm
 Z₂ nr of wormwheel teeth = Z₁ · i
 β helix angle
 m_x normal module
 η_d(1400) dynamic efficiency with n₁=1400rpm
 η_s static efficiency
 Cr Instantaneous Static max peak torque

	irreversibility	
	dynamic	static
B > 20°	total reversibility	
10° < B < 20°	high dynamic reversibility	almost total reversibility - quick return
8° < B < 10°	high dynamic reversibility, low irreversibility	quick return
5° < B < 8°	low dynamic reversibility, but easy in case of vibrations	good reversibility and poor self-locking
3° < B < 5°	low dynamic reversibility, good irreversibility	very low reversibility and good irreversibility
1° < B < 3°	total irreversibility	

LUBRICATION

		QUB0030	QUB0040	QUB0050	QUB0063	QUB0075	QUB0090	QUB0110	QUB0130	QUB0150	STADIO-63	STADIO-71	STADIO-80	STADIO-90
		synthetic oil						mineral oil			synthetic oil			
T°C		-5°C to + 50°C						-5°C to +50°C			-5°C to + 50°C			
ISO VG...		ISO Vg320						ISO Vg460			ISO Vg320			
oil type	KLUBER	Klubersynth GH6-320						Klubersynth GH6-460			Klubersynth GH6-320			
	SHELL	TIVELA OIL Sc320						OMALA OIL 460			TIVELA OIL Sc320			
	SERVO							SERVOMESH Sp460						
	MOBIL	GLYGOYLE 30						MOBIL GEAR 634			GLYGOYLE 30			
	CASTROL	ALPHASYN Pg320						ALPHA MAX 460			ALPHASYN Pg320			
	BP	ENERGOL SG XP 320						ENERGOL GR-XP-460			ENERGOL SG-XP 320			
oil quantity (lit)	B3							3	4.5	7				
	B8	0.04	0.08	0.15	0.30	0.55	1.00	2.2	3.3	5.1	0.16	0.25	0.28	0.28
	V5							2.2	3.3	5.1				
	V6							2.2	3.3	5.1				
	B6-B7							2.2	3.3	5.1				
	Maintenance	pre-lubricated by Rotomotive						Supplied mineral oil. Can be supplied Synthetic oil at an extra cost			pre-lubricated by Rotomotive			
	none, lifetime lubrication						oil change after 400 working hours, then every 4000 working hours			none, lifetime lubrication				

tab. 3

Unless otherwise specified, wormgear QUBO sizes 30 to 90 are supplied with long life synthetic lubrication and they do not require any maintenance. However, if any topping up is required, it can be done using the filler hole provided on the gearboxes.

QUBO110, QUBO130 and QUBO150 however must be filled with oil prior to be operated.

The use of oil instead of grease drastically improves the lubrication effectiveness and efficiency, particularly in the "limit layer" condition as well as in highly intermittent applications.

Furthermore synthetic oil lubrication assures a much wider range of low and high operating temperatures.

With the use of synthetic oil the limits of temperature rise during operation are determined by the properties of the seal material as well as the thermal expansion of the gearbox case (tab 3)

All units are supplied with plugs for filling, discharging and checking the level of the oil. Furthermore, a breather plug is also supplied with QUB063, QUB075, QUB090, QUB0110 QUB0130 and QUB0150.

Before start-up it is essential to replace the blind plug on the upper side of the unit with the breather plug. This operation is mandatory on QUBO110, 130 and 150.

It is however advisable that solid plugs be used in ratios up to 40 as there may be some seepage of oil from the breather plug at certain speeds due to churning action of the gears.

For some applications, breather plug may be a must in spite of possibility of oil leakage. For such case please contact Rotomotive.



MOUNTING POSITIONS

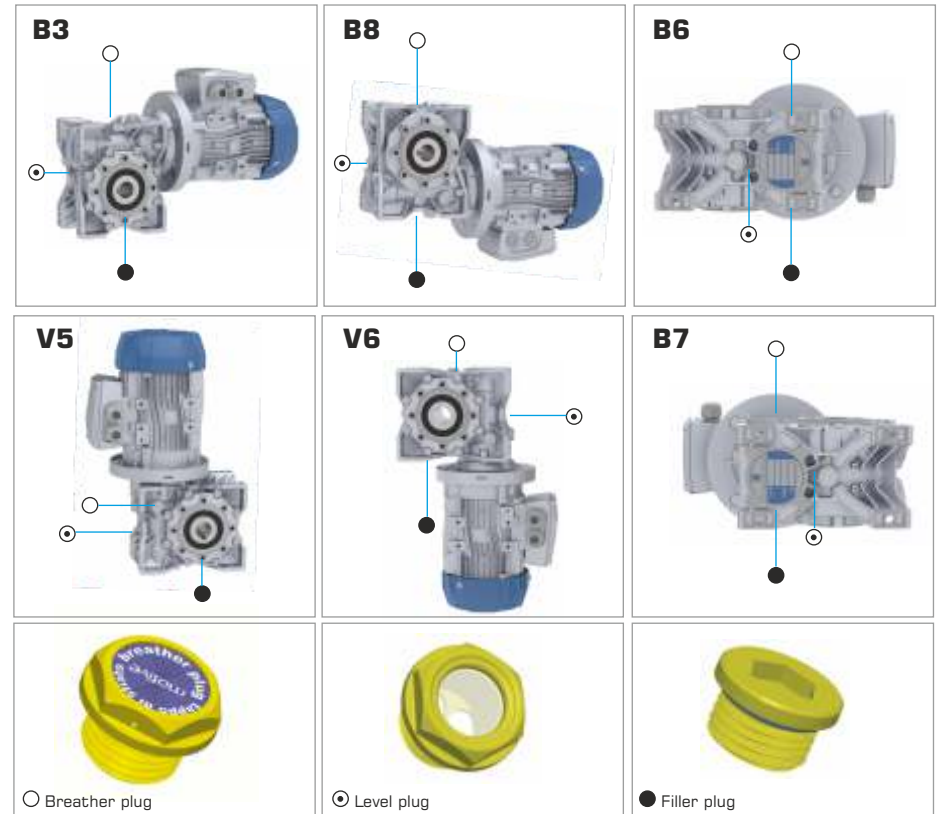

Upon request spring loaded breather plug to be supplied.

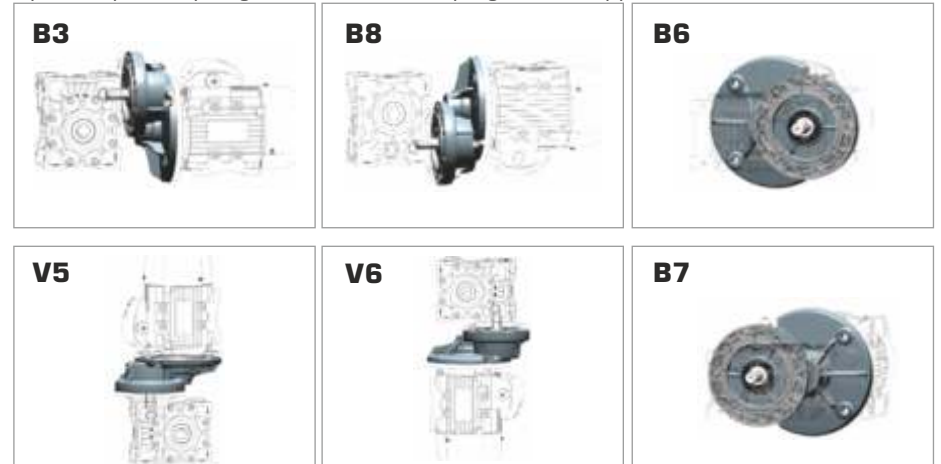

Like gearboxes, STADIO is supplied by Rotomotive with synthetic oil suitable for the whole life time. No maintenance requested.

Rated output torque M_{n2} [Nm]

Torque transmitted under uniform loading and with reference to the input speed $n1$ and the corresponding output speed $n2$

The output torque can be calculated with the following formula:

$$M_{n2} = \frac{P_{n1} \text{ [kW]} \cdot 9550}{N_2} \cdot h_d$$

Torque Demand M_{r2} (Nm)

Torque calculated based on application requirements. It must be $\leq M_{n2}$ of the chosen QUBO unit.

Input Power P_{n1} [kW]

This is the power value of the motor applied to the input shaft and corresponding to a certain input speed $n1$, a service factor $f_s = 1$ and a duty cycle S_1

It is even possible to calculate the motor size necessary by using the formula:

$$P_{n1} \text{ [kW]} = \frac{M_{r2} \cdot n_2}{9550 \cdot h_d}$$

Since the value calculated in this way may not be identical to the power of the motors actually available in the IS/ IEC standardized motors, it will be necessary to choose a motor which has the next higher power rating. Please refer to Rotomotive Revvo series motors for more information on standardized power ratings.

Gear ratio i

It is the relationship of the input speed $n1$ and the output speed $n2$

$$i = \frac{n1}{n2}$$

In the QUBO units with pre-stage reduction (QUBO+PC) the total ratio is given by the PC pre-stage reduction

ratio multiplied by the QUBO unit ratio. In the combined QUBO units (QUBO+QUBO) the total ratio is the result of the product of the ratio of the two single boxes composing the combined unit.

Input Speed n_1 [rpm]

It is the speed at which QUBO unit is driven or the speed of the motor.

Output Speed n_2 [rpm]

It is the rotation speed of the output shaft.

Service Factor f_s

It is a numeric value describing the QUBO unit service duty with some approximation. It takes in to consideration:

- The daily working hours **h/d**
- The load classification (see table 2) and the moment of inertia of the driven mass
- The number of starts per hour **s/h**
- In case of brake motors, it is necessary to multiply the service factor value deduced from graph 2 by 1.12
- The significance of the application in terms of safety, for example lifting of parts

In the graph 2 the service factor f_{sr} required by a certain application can be determined after having selecting proper "Daily working hours" (h/d) column and by intersecting the number of starts per hour (s/h) and one of the a, b or c curves. The curves a, b and c are linked with the load classification described in the table 2

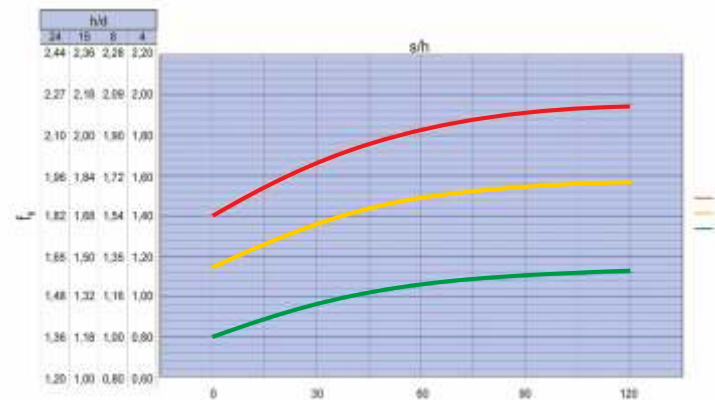

tab. 2

load classification	application
c Uneven operation, heavy loads, larger mass to be accelerated	Conveyors with violent jerks, compressors and alternating pumps with one or more cylinders, machinery for bricks, tiles and clay, kneaders, milling machines, lifting machines, lifting winches with buckets rotary furnaces, heavy fans or mining purposes, mixers for heavy materials, machine tools, planning machines, alternating saws, shears, tumbling barrels, vibrators, shredders
b Starting with moderate loads uneven operating conditions, medium size mass to be accelerated	Belt conveyers with varied load with transfer for bridge trucks of light duty, leveling machines, shakers and mixers for liquid with variable density and viscosity machines for the food industry (kneading through, mincing machines, slicing machines, etc) sifting machines for sand gravel, textile industry machines, cranes, hoists, goods lifts, fertilizer scrapers, concrete mixers, folding machines, winches, crane mechanisms
a Easy starting, smooth operation, small mass to be accelerated	Belt conveyers for light material, centrifugal pump, rotary gear pump, screw feeders for light materials, lifts, bottling machines, controls of machine tools, fans, power generators, filters, small mixers.

If, after the selection of the right M_{r2} and n_2 in the following performance tables, a QUBO unit whose service factor f_s is = of the requested one f_{sr} , is not found, then it is advisable to choose a QUBO unit in which $M_{n2} > M_{r2}$

In order to satisfy f_{sr} another QUBO unit whose output torque is = M_{c2} (required torque) can also be chosen.

$$M_{c2} = M_{r2} \cdot f_{sr}$$

Note: This rule is valid only if the new QUBO unit that has been selected in this way has a service factor $f_s = 1$ in the performance tables.

Essentially, the value of f_s in the



performance tables refers to a case in which the effective torque requested by the application M_{r2} matches perfectly with the M_{n2} listed in this catalogue.



Whenever the torque indicated in the performance table is higher than the requested one. The offered service factor of the performance table can be increased according to the formula:



$$f_s \text{ real} = \frac{f_s \text{ on the table} \cdot M_{n2} \text{ on the Table}}{M_{r2}}$$

The value of f_s calculated in this way must be = f_{sr} .



QUBO PERFORMANCE TABLES



P ₁ 0,06 kW											
n ₂ [rpm]	M ₂ [Nm]	f _s	i								
186,7	2,6	6,9	7,5	QUBO030	56A-4						
140,0	3,4	5,4	10								
93,3	4,7	3,8	15								
70,0	6	3,0	20								
56,0	7	3,0	25								
46,7	8	2,5	30								
35,0	9,7	1,9	40								
28,0	11	1,5	50								
23,3	13	1,3	60								
17,5	14	0,9	80								
4,70	62	1,3	300					30X10	QUBO030	+	56A-4
3,50	73	0,9	400					40X10	QUBO040		
2,80	103	0,6	500					25X20	QUBO040		56A-4
2,30	113	0,7	600					30X20	QUBO040		56A-4
1,90	123	0,6	750					50X15	QUBO040		56A-4
1,6	132	1,0	900					60X15	QUBO030	+	56A-4
1,2	181	0,7	1200					40X30	QUBO050		
0,9	214	0,7	1500	50X30	QUBO050		56A-4				
0,8	227	0,7	1800	60X30	QUBO050		56A-4				
0,9	221	1,1	1500	50X30	QUBO030	+	56A-4				
0,8	235	0,9	1800	60X30	QUBO063						
0,6	303	0,8	2400	60X40	QUBO063		56A-4				
0,4	420	0,6	3000	60X50	QUBO063		56A-4				
0,5	362	0,7	4000	80X50	QUBO063		56A-4				



P ₁ 0,09 kW							
n ₂ [rpm]	M ₂ [Nm]	f _s	i				
373,3	2	6,5	7,5	QUBO030	56A-4		
280,0	2,6	5,0	10				
186,7	3,7	3,5	15				
140,0	4,8	2,5	20				
112,0	5,7	2,8	25				
93,3	6,5	2,3	30				
80,0	7,1	2,5	35				
70,0	8,1	1,7	40				
60,0	9	2,0	45				
56,0	10	2,0	50				
50,0	11	1,4	60				
46,7	11	1,1	60				
46,7	12	1,7	30				
17,5	13	0,9	80				
35,0	14	1,2	40				
28,0	17	1,0	50				
23,3	19	0,9	60				
4,70	93	0,8	300	30X10	QUBO030+	QUBO040	56B-4
3,50	112	1,2	400	40X10	QUBO030		
2,80	133	1,0	500	50X10	QUBO030		56B-4
2,30	141	0,9	600	60X10	QUBO050		56B-4
1,9	186	0,8	750	50X15	QUBO050		56B-4
1,60	198	0,7	900	60X15	QUBO050		56B-4
1,60	199	1,0	900	60X15	QUBO030	+	56B-4
1,20	263	0,9	1200	60X20	QUBO063		
0,93	332	0,7	1500	50X30	QUBO063		56B-4

P ₁ 0,13 kW											
n ₂ [rpm]	M ₂ [Nm]	f _s	i								
186,7	5,2	3,4	7,5	QUBO030	56A-2						
140,0	6,7	2,7	10								
93,3	9,5	1,9	15								
70,0	12	1,5	20								
56,0	14	1,5	25								
46,7	16	1,3	30								
35,0	19	0,9	40								
28,0	23	0,8	50								
23,3	28	0,8	60								
17,5	34	1,0	80								
14,0	38	0,8	100								
23,3	29	2,3	60								
17,5	35	1,9	80								
14,0	40	1,4	100								
4,70	137	1,2	300					30X10	QUBO030	+	56A-4
3,50	162	0,9	400					40X10	QUBO050		
2,80	192	0,7	500					50X10	QUBO050		56A-4
2,80	194	1,3	500	50X10	QUBO030	+	56A-4				
2,30	206	1,1	600	60X10	QUBO063						
1,87	271	0,9	750	50X15	QUBO063		56A-4				
1,60	362	1,2	900	60X15	QUBO040		56A-4				
1,20	473	0,9	1200	60X20	QUBO075		56A-4				
0,8	686	0,9	1800	60X30	QUBO040		56A-4				
0,6	817	0,9	2400	80X30	QUBO090		56A-4				
0,5	942	1,2	3000	100X30	QUBO050	+	56A-4				
0,4	1197	1,0	4000	100X40	QUBO110						
0,3	1424	0,8	5000	100X50	QUBO110		56A-4				



QUBO PERFORMANCE TABLES



P ₁ 0,18 kW						
n ₂ [rpm]	M ₂ [Nm]	f _s	i			
373,3	4	3,2	7,5	QUBO030	63A-2	
280,0	5,2	2,5	10		63A-2	
186,7	7,5	1,7	15		63A-2	
186,7	7,8	2,3	7,5		63B-4	
140,0	10	1,8	10		63B-4	
140,0	10	1,3	20		63A-2	
112,0	11	1,4	25		63A-2	
93,3	13	1,1	30		63A-2	
93,3	14	1,3	15		63B-4	
70,0	16	0,9	40		63A-2	
70,0	18	1,0	20		63B-4	
56,0	21	1,0	25		63B-4	
46,7	24	0,8	30		63B-4	
93,3	14	2,4	30		63A-2	
70,0	18	1,8	40		63A-2	
70,0	19	2,0	20	63B-4		
56,0	21	1,4	50	63A-2		
56,0	23	1,7	25	63B-4		
46,7	26	1,7	30	63B-4		
45,0	29	1,5	20	71A-6		
35,0	32	1,3	40	63B-4		
36,0	34	1,3	25	71A-6		
30,0	38	1,3	30	71A-6		
28,0	38	1,0	50	63B-4		
23,3	43	0,8	60	63B-4		
22,5	47	1,0	40	71A-6		
46,7	24	2,1	60	63A-2		
35,0	30	1,5	80	63A-2		
35,0	33	2,3	40	63B-4		
28,0	34	1,2	100	63A-2		
28,0	39	1,9	50	63B-4		
23,3	43	1,6	60	63B-4		
17,5	52	1,2	80	63B-4		
18,0	56	1,4	50	71A-6		
14,0	60	0,9	100	63B-4		
15,0	63	1,1	60	71A-6		
11,2	75	0,9	80	71A-6		
4,70	192	1,1	300	30X10	QUBO030	63B-4
3,50	227	1,0	400	40X10	+	63B-4
2,80	269	0,8	500	50X10	QUBO063	63B-4
2,30	351	1,1	600	60X10	QUBO040	63B-4
1,90	386	0,9	750	100X7.5	+	63B-4
1,60	501	0,8	900	60X15	QUBO075	63B-4
1,20	659	1,0	1200	60X20	QUBO048	63B-4
0,90	877	0,8	1500	50X30	QUBO090	63B-4
0,80	985	1,5	1800	60X30	QUBO058	63B-4
0,60	1197	1,1	2400	80X30	QUBO110	63B-4



P ₁ 0,25 kW						
n ₂ [rpm]	M ₂ [Nm]	f _s	i			
373,3	5,6	2,3	7,5	QUBO030	63B-2	
280,0	7,2	1,8	10		63B-2	
186,7	10	1,3	15		63B-2	
140,0	13	0,9	20		63B-2	
112,0	16	1,0	25		63B-2	
93,3	18	0,8	30		63B-2	
186,7	11	3,6	7,5		71A-4	
140,0	14	2,8	10		71A-4	
120,0	17	2,6	7,5		71B-6	
93,3	21	1,9	15		71A-4	
90,0	22	2,0	10		71B-6	
70,0	27	1,5	20		71A-4	
60,0	31	1,4	15		71B-6	
56,0	32	1,2	25		71A-4	
46,7	36	1,3	30		71A-4	
45,0	40	1,1	20	71B-6		
35,0	44	0,9	40	71A-4		
36,0	48	0,9	25	71B-6		
30,0	53	0,9	30	71B-6		
70,0	27	2,7	20	71A-4		
56,0	32	2,2	25	71A-4		
46,7	37	2,3	30	71A-4		
45,0	40	1,9	20	71B-6		
35,0	42	1,1	80	63B-2		
35,0	46	1,7	40	71A-4		
28,0	48	0,8	100	63B-2		
36,0	48	1,5	25	71B-6		
30,0	54	1,7	30	71B-6		
28,0	54	1,4	50	71A-4		
23,3	60	1,1	60	71A-4		
22,5	67	1,2	40	71B-6		
17,5	72	0,9	80	71A-4		
18,0	78	1,0	50	71B-6		
15,0	88	0,8	60	71B-6		
28,0	56	2,4	50	71A-4		
23,3	63	2,0	60	71A-4		
17,5	78	1,6	80	71A-4		
18,0	81	1,8	50	71B-6		
14,0	87	1,4	100	71A-4		
15,0	92	1,5	60	71B-6		
11,3	110	1,2	80	71B-6		
9,0	125	1,0	100	71B-6		
7,00	158	1,4	400	40X10	QUBO038	63B-2
5,60	187	1,2	500	50X10	QUBO063	63B-2
3,50	377	1,1	400	40X10	QUBO048	71A-4
2,80	450	0,8	500	50X10	QUBO075	71A-4
2,30	489	1,2	600	60X10	QUBO040	71A-4
1,90	538	0,9	750	100X7.5	+	71A-4
1,60	720	0,8	900	60X15	QUBO090	71A-4
1,20	969	1,3	1200	60X20	QUBO050	71A-4
0,90	988	1,2	1500	100X15	+	71A-4
0,80	1368	1,1	1800	60X30	QUBO110	71A-4
0,6	1881	1,0	2400	60X40	QUBO068	71A-4
0,5	2257	1,0	3000	60X50	QUBO130	71A-4

P ₁ 0,37 kW						
n ₂ [rpm]	M ₂ [Nm]	f _s	i			
373,3	8,4	3,3	7,5	QUBO040	71A-2	
280,0	11	2,6	10		71A-2	
186,7	16	1,9	15		71A-2	
186,7	16	2,4	7,5		71B-4	
140,0	21	1,9	10		71B-4	
140,0	21	1,4	20		71A-2	
112,0	25	1,1	25		71A-2	
93,3	31	1,3	15		71B-4	
70,0	39	1,0	20		71B-4	
56,0	47	0,8	25		71B-4	
46,7	53	0,8	30		71B-4	
140,0	22	3,3	10		71B-4	
112,0	25	2,0	25		71A-2	
120,0	25	3,3	7,5		80A-6	
93,3	29	2,2	30		71A-2	
93,3	31	2,4	15	71B-4		
90,0	33	2,5	10	80A-6		
70,0	37	1,6	40	71A-2		
70,0	40	1,8	20	71B-4		
56,0	44	1,2	50	71A-2		
60,0	47	1,8	15	80A-6		
56,0	48	1,5	25	71B-4		
46,7	50	1,0	60	71A-2		
46,7	55	1,5	30	71B-4		
45,0	60	1,3	20	80A-6		
35,0	62	0,7	80	71A-2		
35,0	68	1,1	40	71B-4		
36,0	72	1,0	25	80A-6		
30,0	80	1,1	30	80A-6		
28,0	80	0,9	50	71B-4		
23,3	89	0,8	60	71B-4		
45,0	60	2,4	20	80A-6		
35,0	71	2,1	40	71B-4		
36,0	74	1,9	25	80A-6		
30,0	82	2,1	30	80A-6		
28,0	83	1,6	50	71B-4		
23,3	94	1,4	60	71B-4		
22,5	102	1,6	40	80A-6		
17,5	115	1,1	80	71B-4		
18,0	120	1,2	50	80A-6		
14,0	129	0,9	100	71B-4		
15,0	137	1,0	60	80A-6		
18,0	126	1,8	50	80A-6		
15,0	144	1,5	60	80A-6		
11,3	173	1,2	80	80A-6		
9,0	196	1,0	100	80A-6		
4,70	449	1,0	300	30X10	QUBO040+	71B-4
3,50	559	0,7	400	40X10	QUBO075	71B-4
4,70	451	1,5	300	30X10	+	71B-4
3,50	560	1,2	400	40X10	QUBO040	71B-4
2,80	668	0,9	500	50X10	+	71B-4
2,30	724	0,8	600	60X10	QUBO090	71B-4
1,90	764	1,3	750	100X7.5	QUBO050	71B-4
1,60	1105	1,2	900	60X15	+	71B-4
1,20	1434	0,8	1200	60X20	QUBO110	71B-4
0,9	1918	1,0	1500	50X30	QUBO068	71B-4
0,8	2199	1,0	1800	60X30	QUBO130	71B-4



QUBO PERFORMANCE TABLES



P ₁ 0,55 kW							
n ₂ [rpm]	M ₂ [Nm]	f _s	i				
373,3	13	2,2	7,5	QUB0040		71B-2	
280,0	17	1,8	10			71B-2	
186,7	24	1,3	15			71B-2	
140,0	31	0,9	20			71B-2	
112,0	37	0,8	25			71B-2	
186,7	25	2,9	7,5			80A-4	
140,0	31	1,7	20			71B-2	
140,0	32	2,2	10			80A-4	
112,0	38	1,4	25			71B-2	
120,0	38	2,2	8			80B-6	
93,3	43	1,5	30	QUB0050		71B-2	
93,3	46	1,6	15			80A-4	
90,0	49	1,7	10			80B-6	
70,0	55	1,1	40			71B-2	
70,0	59	1,2	20			80A-4	
56,0	65	0,8	50			71B-2	
60,0	69	1,2	15			80B-6	
56,0	71	1,0	25			80A-4	
46,7	74	0,7	60			71B-2	
46,7	81	1,0	30			80A-4	
45,0	89	0,9	20	QUB0063		80B-6	
70,0	56	1,9	40			71B-2	
70,0	61	2,2	20			80A-4	
56,0	67	1,5	50			71B-2	
60,0	71	2,2	15			80B-6	
56,0	73	1,8	25			80A-4	
46,7	77	1,2	60			71B-2	
46,7	83	1,9	30			80A-4	
45,0	90	1,6	20			80B-6	
35,0	95	0,9	80			71B-2	
35,0	105	1,4	40	80A-4			
28,0	109	0,7	100	QUB0075		71B-2	
36,0	109	1,3	25			80B-6	
30,0	123	1,4	30			80B-6	
28,0	124	1,1	50			80A-4	
23,3	140	0,9	60			80A-4	
22,5	152	1,1	40			80B-6	
35,0	108	2,0	40			80A-4	
30,0	128	2,0	30			80B-6	
28,0	129	1,6	50			80A-4	
23,3	146	1,4	60			80A-4	
22,5	159	1,5	40	80B-6			
17,5	180	1,1	80	QUB0090		80A-4	
18,0	187	1,2	50			80B-6	
14,0	206	0,9	100			80A-4	
15,0	214	1,0	60			80B-6	
17,5	189	1,5	80			80A-4	
18,0	198	2,0	50			80B-6	
14,0	221	1,2	100			80A-4	
15,0	224	1,6	60			80B-6	
11,3	275	1,1	80			80B-6	
9,0	315	0,9	100			80B-6	
9,30	335	2,0	300	30X10	QUB0040	71B-2	
7,00	417	1,5	400	40X10	+	71B-2	
5,60	334	1,2	500	50X10	QUB0090	71B-2	
4,70	688	2,0	300	30X10		80A-4	
3,50	888	1,4	400	40X10	QUB0050	80A-4	
2,80	996	1,1	500	50X10	+	80A-4	
2,30	1129	1,0	600	60X10	QUB0110	80A-4	
1,90	1136	0,9	750	100X7.5		80A-4	
1,2	2385	1,0	1200	40X30	QUB0060+	80A-4	
					QUB0130		



P ₁ 0,75 kW							
n ₂ [rpm]	M ₂ [Nm]	f _s	i				
373,3	17	3,0	7,5	QUB0050		80A-2	
280,0	23	2,4	10			80A-2	
186,7	33	1,7	15			80A-2	
186,7	34	2,1	7,5			80B-4	
140,0	42	1,3	20			80A-2	
140,0	44	1,6	10			80B-4	
112,0	51	1,0	25			80A-2	
93,3	58	1,1	30			80A-2	
93,3	63	1,2	15			80B-4	
70,0	81	0,9	20			80B-4	
140,0	43	2,3	20	QUB0063		80A-2	
112,0	52	1,8	25			80A-2	
120,0	52	2,9	7,5			90S-6	
93,3	60	2,0	30			80A-2	
93,3	64	2,2	15			80B-4	
90,0	68	2,3	10			90S-6	
70,0	77	1,4	40			80A-2	
70,0	83	1,6	20			80B-4	
56,0	91	1,1	50			80A-2	
60,0	97	1,6	15			90S-6	
56,0	100	1,3	25	QUB0075		80B-4	
46,7	104	0,9	60			80A-2	
46,7	114	1,4	30			80B-4	
45,0	123	1,2	20			90S-6	
35,0	143	1,0	40			80B-4	
36,0	149	0,9	25			90S-6	
30,0	167	1,0	30			90S-6	
60,0	98	2,4	15			80B-4	
56,0	102	2,0	25			80B-4	
46,7	109	1,3	60			80A-2	
46,7	117	2,0	30	80B-4			
45,0	126	1,9	20	90S-6			
35,0	147	1,5	40	QUB0090		80B-4	
36,0	153	1,4	25			90S-6	
28,0	156	0,8	100			80A-2	
30,0	174	1,5	30			90S-6	
28,0	177	1,2	50			80B-4	
23,3	200	1,0	60			80B-4	
22,5	216	1,1	40			90S-6	
35,0	141	1,6	80			80A-2	
28,0	166	1,2	100			80A-2	
30,0	179	2,6	30			90S-6	
28,0	184	1,8	50	80B-4			
23,3	212	1,5	60	80B-4			
22,5	226	1,8	40	90S-6			
17,5	258	1,1	80	80B-4			
18,0	271	1,4	50	90S-6			
14,0	302	0,9	100	80B-4			
15,0	306	1,1	60	90S-6			
15,0	325	2,1	60	90S-6			
11,3	401	1,4	80	90S-6			
9,0	462	1,1	100	90S-6			
9,30	469	2,8	300	30X10		80A-2	
7,00	605	2,1	400	40X10	QUB0050	80A-2	
5,60	679	1,6	500	50X10	+	80A-2	
4,70	939	1,5	300	30X10	QUB0110	80B-4	
3,50	1211	1,1	400	40X10		80B-4	
2,30	1767	1,0	600	60X10	QUB0063	80B-4	
1,90	2067	1,0	750	100X7.5	+	80B-4	
1,60	2370	1,0	900	60X15	QUB0130	80B-4	

P ₁ 1,1 kW								
n ₂ [rpm]	M ₂ [Nm]	f _s	i					
373,3	25	2,1	7,5	QUB0050		80B-2		
280,0	33	1,6	10			80B-2		
186,7	48	1,2	15			80B-2		
140,0	62	0,9	20			80B-2		
186,7	48	2,1	15			80B-2		
186,7	50	2,6	7,5			90S-4		
140,0	63	1,6	20			80B-2		
140,0	65	2,0	10			90S-4		
120,0	76	2,0	7,5			90L-6		
112,0	77	1,2	25			80B-2		
93,3	88	1,4	30	QUB0063		80B-2		
93,3	93	1,5	15			90S-4		
90,0	99	1,5	10			90L-6		
70,0	113	1,0	40			80B-2		
70,0	122	1,1	20			90S-4		
60,0	142	1,1	15			90L-6		
56,0	146	0,9	25			90S-4		
46,7	167	1,0	30			90S-4		
45,0	180	0,8	20			90L-6		
112,0	78	1,9	25			QUB0075		80B-2
93,3	90	1,9	30	80B-2				
93,3	96	2,1	15	90S-4				
90,0	100	2,3	10	90L-6				
70,0	116	1,4	40	80B-2				
70,0	123	1,7	20	90S-4				
56,0	139	1,1	50	80B-2				
60,0	144	1,6	15	90L-6				
56,0	150	1,3	25	90S-4				
46,7	160	0,9	60	80B-2				
46,7	171	1,3	30	90S-4				
45,0	184	1,3	20	90L-6				
35,0	216	1,0	40	90S-4				
36,0	225	1,0	25	90L-6				
30,0	256	1,0	30	90L-6				
35,0	207	1,1	80	QUB0090		80B-2		
35,0	225	1,6	40			90S-4		
36,0	231	1,6	25			90L-6		
28,0	244	0,8	100			80B-2		
30,0	263	1,8	30			90L-6		
28,0	270	1,3	50			90S-4		
23,3	311	1,0	60			90S-4		
22,5	331	1,2	40			90L-6		
18,0	397	1,0	50			90L-6		
15,0	448	0,8	60			90L-6		
28,0	281	2,3	50	QUB0110		90S-4		
23,3	324	1,9	60			90S-4		
22,5	345	2,3	40			90L-6		
17,5	402	1,3	80			90S-4		
18,0	414	1,8	50			90L-6		
14,0	473	1,0	100			90S-4		
15,0	476	1,4	60			90L-6		
11,3	588	1,0	80			90L-6		
9,30	688	1,9	300			30X10	QUB0050	80B-2
7,00	888	1,4	400			40X10	+	80B-2
5,60	996	1,1	500	50X10	QUB0110	80B-2		
4,70	408	2,1	80	BOX130		90S-4		
14,0	480	1,5	100			90S-4		
11,6	598	1,4	80			90L-6		
9,0	689	1,1	100			90L-6		
4,7	1343	1,2	300			30X10	QUB0063+	90S-4
3,5	1731	1,0	400	40X10	QUB0130	90S-4		
2,8	2358	1,0	500	50X10		90S-4		



QUBO PERFORMANCE TABLES



P ₁ 1,5 kW							
n ₂ [rpm]	M ₂ [Nm]	f _s	i				
373,3	35	2,7	7,5	QUBO063	90S-2		
280,0	46	2,1	10		90S-2		
186,7	66	1,6	15		90S-2		
186,7	68	1,9	7,5		90L-4		
140,0	86	1,2	20		90S-2		
140,0	89	1,5	10		90L-4		
112,0	105	0,9	25		90S-2		
93,3	120	1,0	30		90S-2		
93,3	127	1,1	15		90L-4		
70,0	166	0,8	20		90L-4		
280,0	46	3,1	10	90S-2			
186,7	67	2,2	15	90S-2			
140,0	87	1,8	20	90S-2			
140,0	90	2,2	10	90L-4			
120,0	105	2,0	7,5	100LA-6			
112,0	106	1,4	25	90S-2			
93,3	123	1,4	30	90S-2			
93,3	130	1,5	15	90L-4			
90,0	137	1,7	10	100LA-6			
70,0	158	1,0	40	90S-2			
70,0	168	1,3	20	90L-4			
56,0	189	0,8	50	90S-2			
60,0	196	1,2	15	100LA-6			
56,0	205	1,0	25	90L-4			
46,7	218	0,7	60	90S-2			
46,7	233	1,0	30	90L-4			
90,0	138	2,7	10	100LA-6			
70,0	172	2,1	20	90L-4			
56,0	194	1,4	50	90S-2			
60,0	201	2,1	15	100LA-6			
56,0	210	1,6	25	90L-4			
46,7	227	1,1	60	90S-2			
46,7	239	1,7	30	90L-4			
45,0	258	1,5	20	100LA-6			
35,0	307	1,2	40	90L-4			
36,0	314	1,2	25	100LA-6			
30,0	358	1,3	30	100LA-6			
28,0	368	0,9	50	90L-4			
23,3	424	0,8	60	90L-4			
46,7	236	2,0	60	90S-2			
45,0	264	2,7	20	100LA-6			
35,0	299	1,3	80	90S-2			
35,0	319	2,2	40	90L-4			
36,0	322	2,4	25	100LA-6			
28,0	353	1,0	100	90S-2			
30,0	363	2,3	30	100LA-6			
28,0	384	1,7	50	90L-4			
23,3	442	1,4	60	90L-4			
22,5	471	1,7	40	100LA-6			
17,5	548	0,9	80	90L-4			
18,0	565	1,3	50	100LA-6			
15,0	649	1,1	60	100LA-6			
22,5	478	2,3	40	100LA-6			
18,0	573	1,8	50	100LA-6			
17,5	557	1,5	80	90L-4			
15,0	659	1,4	60	100LA-6			
14,0	655	1,1	100	90L-4			
11,3	815	1,1	80	100LA-6			
4,7	1831	1,0	300	30X10	QUBO063+	90L-4	QUBO130



P ₁ 2,2 kW							
n ₂ [rpm]	M ₂ [Nm]	f _s	i				
373,3	51	1,8	7,5	QUBO063	90L-2		
280,0	67	1,5	10		90L-2		
186,7	97	1,1	15		90L-2		
373,3	51	2,5	7,5	QUBO075	90L-2		
280,0	68	2,1	10		90L-2		
186,7	98	1,5	15		90L-2		
186,7	100	1,8	7,5	QUBO075	100LA-4		
140,0	128	1,3	20		90L-2		
140,0	132	1,5	10		100LA-4		
112,0	156	1,0	25	90L-2			
93,3	180	0,9	30	90L-2			
93,3	191	1,0	15	100LA-4			
186,7	101	2,9	7,5	QUBO090	100LA-4		
140,0	131	2,0	20		90L-2		
140,0	134	2,3	10		100LA-4		
120,0	156	2,2	7,5	QUBO090	112M-6		
112,0	159	1,6	25		90L-2		
93,3	185	1,7	30		90L-2		
93,3	194	1,9	15	QUBO090	100LA-4		
90,0	203	1,8	10		112M-6		
70,0	237	1,2	40		90L-2		
70,0	252	1,4	20	QUBO110	100LA-4		
56,0	285	0,9	50		90L-2		
60,0	294	1,4	15		112M-6		
56,0	308	1,1	25	QUBO110	100LA-4		
46,7	351	1,2	30		100LA-4		
45,0	378	1,0	20		112M-6		
112,0	163	3,1	25	QUBO110	90L-2		
93,3	187	3,0	30		90L-2		
90,0	205	3,5	10		112M-6		
70,0	246	2,1	40	QUBO130	90L-2		
70,0	255	2,5	20		100LA-4		
56,0	296	1,7	50		90L-2		
60,0	298	2,6	15	QUBO110	112M-6		
56,0	315	2,2	25		100LA-4		
46,7	347	1,4	60		90L-2		
46,7	356	2,0	30	QUBO130	100LA-4		
45,0	388	1,9	20		100LA-4		
35,0	468	1,5	40		112M-6		
36,0	473	1,6	25	QUBO130	100LA-4		
30,0	532	1,6	30		112M-6		
28,0	563	1,2	50		100LA-4		
23,3	648	1,0	60	QUBO130	100LA-4		
36,0	479	2,2	25		112M-6		
35,0	468	2,2	40		100LA-4		
35,0	438	1,3	80	QUBO130	90L-2		
30,0	546	2,1	30		112M-6		
28,0	563	1,7	50		100LA-4		
28,0	525	1,0	100	QUBO150	90L-2		
23,3	648	1,4	60		100LA-4		
22,5	700	1,6	40		112M-6		
18,0	840	1,2	50	QUBO150	112M-6		
17,5	816	1,0	80		100LA-4		
15,0	966	1,0	60		112M-6		
28,0	570	2,5	50	QUBO150	100LA-4		
23,3	657	1,9	60		100LA-4		
17,5	816	1,4	80		100LA-4		
14,0	960	1,0	100	100LA-4			



P ₁ 3 kW							
n ₂ [rpm]	M ₂ [Nm]	f _s	i				
373,3	70	1,9	7,5	QUBO075	90L-2		100L-2
280,0	92	1,6	10		90L-2		100L-2
186,7	137	1,4	7,5		90L-2		100LB-4
140,0	180	1,1	10	QUBO090	90L-2		100LB-4
93,3	261	0,8	15		90L-2		100LB-4
373,3	71	3,0	7,5		90L-2		100L-2
280,0	92	2,6	10	QUBO090	100LA-4		100L-2
186,7	138	2,1	7,5		90L-2		100LB-4
140,0	182	1,7	10		100LA-4		100LB-4
93,3	264	1,4	15	QUBO090	90L-2		100LB-4
70,0	344	1,0	20		90L-2		100LB-4
56,0	420	0,8	25		100LA-4		100LB-4
46,7	479	0,9	30	QUBO110	100LA-4		100LB-4
120,0	212	3,1	7,5		90L-2		132S-6
93,3	264	2,5	15		100LA-4		100LB-4
90,0	280	2,5	10	QUBO110	112M-6		132S-6
70,0	348	1,9	20		90L-2		100LB-4
60,0	406	1,9	15		90L-2		132S-6
56,0	430	1,6	25	QUBO110	100LA-4		100LB-4
46,7	485	1,5	30		112M-6		100LB-4
45,0	528	1,4	20		90L-2		132S-6
35,0	638	1,1	40	QUBO110	100LA-4		100LB-4
28,0	767	0,9	50		90L-2		100LB-4
90,0	280	3,4	10		112M-6		132S-6
60,0	406	2,6	15	QUBO130	100LA-4		132S-6
56,0	430	2,2	25		100LA-4		100LB-4
46,7	491	2,1	30		112M-6		100LB-4
45,0	535	1,9	20	QUBO130	90L-2		132S-6
36,0	653	1,6	25		90L-2		132S-6
35,0	638	1,6	40		112M-6		100LB-4
30,0	745	1,6	30	QUBO130	100LA-4		132S-6
28,0	767	1,3	50		100LA-4		100LB-4
23,3	884	1,0	60		90L-2		100LB-4
22,5	955	1,2	40	QUBO150	112M-6		132S-6
17,5	1113	0,8	80		100LA-4		100LB-4
28,0	778	1,8	50		90L-2		100LB-4
23,3	896	1,4	60	QUBO150	100LA-4		100LB-4
17,5	1113	1,0	80		112M-6		100LB-4
14,0	1310	0,8	100		100LA-4		100LB-4



QUBO PERFORMANCE TABLES



P ₁ 4 kW					
n ₂ [rpm]	M ₂ [Nm]	f _s	i		
373,3	93	1,4	7,5	QUBO075	112M-2
280,0	123	1,2	10		112M-2
186,7	182	1,0	7,5		112M-4
140,0	240	0,8	10		112M-4
373,3	94	2,2	7,5	QUBO090	112M-2
280,0	123	1,9	10		112M-2
186,7	184	1,6	7,5		112M-4
140,0	243	1,3	10		112M-4
93,3	352	1,0	15	QUBO110	112M-4
70,0	458	0,8	20		112M-4
140,0	243	2,5	10		112M-4
120,0	283	2,3	7,5		132M-6
93,3	352	1,9	15		112M-4
90,0	374	1,9	10		132M-6
70,0	464	1,4	20		112M-4
60,0	541	1,4	15		132M-6
60,0	573	1,2	25		112M-4
46,7	647	1,1	30		112M-4
120,0	287	3,1	7,5	QUBO130	132M-6
90,0	374	2,6	10		132M-6
60,0	541	2,0	15		132M-6
56,0	573	1,6	25		112M-4
46,7	655	1,6	30		112M-4
45,0	713	1,5	20		132M-6
36,0	870	1,2	25		132M-6
35,0	851	1,2	40		112M-4
28,0	1023	1,0	50		112M-4
23,3	1179	0,8	60		112M-4
28,0	982	1,7	50	QUBO150	112M-4
23,3	1146	1,3	60		112M-4
17,5	1418	0,9	80		112M-4
14,0	1691	0,7	100		112M-4

P ₁ 7,5 kW					
n ₂ [rpm]	M ₂ [Nm]	f _s	i		
186,7	345	1,6	7,5	QUBO110	132M-4
140,0	455	1,3	10		132M-4
93,3	660	1,0	15		132M-4
186,7	349	2,1	7,5		QUBO130
140,0	455	1,8	10	132M-4	
93,3	668	1,4	15	132M-4	
70,0	880	1,0	20	132M-4	
56,0	1074	0,9	25	QUBO150	132M-4
46,7	1228	0,8	30		132M-4
35,0	1596	0,7	40		132M-4
70,0	880	1,5	20		132M-4
56,0	1074	1,1	25		132M-4
46,7	1274	0,9	30		132M-4
35,0	1596	1,0	40	132M-4	

P ₁ 9,3 kW					
n ₂ [rpm]	M ₂ [Nm]	f _s	i		
186,7	440	1,3	7,5	QUBO110	132M-4
186,7	428	1,8	7,5		132M-4
140,0	546	1,5	10	QUBO130	132M-4
93,3	799	1,1	15		132M-4
70,0	1053	0,8	20		132M-4
56,0	1285	0,7	25		132M-4
70,0	1053	1,2	20	QUBO150	132M-4
56,0	1285	0,9	25		132M-4
46,7	1504	0,8	30		132M-4
35,0	1903	0,8	40		132M-4

P ₁ 5,5 kW					
n ₂ [rpm]	M ₂ [Nm]	f _s	i		
186,7	253	2,2	7,5	QUBO110	132S-4
140,0	334	1,8	10		132S-4
93,3	484	1,4	15		132S-4
70,0	638	1,0	20		132S-4
140,0	334	2,5	10	QUBO130	132S-4
93,3	490	1,9	15		132S-4
70,0	645	1,4	20		132S-4
56,0	788	1,2	25		132S-4
46,7	900	1,2	30	QUBO150	132S-4
35,0	1171	0,9	40		132S-4
70,0	645	2,0	20		132S-4
56,0	788	1,5	25		132S-4
46,7	934	1,3	30		132S-4
35,0	1171	1,3	40		132S-4
28,0	1426	1,0	50		132S-4
23,3	1643	0,8	60		132S-4

P ₁ 11 kW					
n ₂ [rpm]	M ₂ [Nm]	f _s	i		
186,7	506	2,3	7,5	QUBO150	160M-4
140,0	645	1,8	10		160M-4
93,3	945	1,3	15		160M-4
70,0	1246	1,0	20		160M-4
56,0	1519	0,8	25		160M-4

P ₁ 15 kW					
n ₂ [rpm]	M ₂ [Nm]	f _s	i		
186,7	691	1,7	7,5	QUBO150	160L-4
140,0	880	1,3	10		160L-4
93,3	1289	0,9	15		160L-4
70,0	1699	0,7	20		160L-4

Design features

STADIO construction is modular and therefore it can be supplied as a separate unit to be mounted on any type of fitted geared motor (PAM). It is not requested any part premounting on the motor shaft.

Like all connectable Rotomotive motors and gearboxes, STADIO is supplied by Rotomotive with synthetic oil suitable for the whole lifetime. No maintenance requested.

Like all connectable gearboxes and motors manufactured by Rotomotive, the whole STADIO range can be mounted in any position with no need of specifications in the order.

The efficiency at rated speed is 98%. The starting efficiency is always less than the efficiency at rated speed.

The pre-stage unit cannot be used by itself, but only coupled with another reduction unit.

A powder paint coat cancels the negative effects of the aluminium porosity and protects the housing from oxidation.

In order to reduce noise, improve efficiency and durability, gears are made of tempered steel 20CrMnTi (UNI7846) case hardened to HRC59-63 and accurately profile ground.

Performance

QUBO+STADIO		=	FORMULA	
final ratio	i	=	QUBO i : x STADIO i :	
final service factor	sf	=	QUBO SF / 2	
final output speed	n_2 [rpm]	=	QUBO n_2 / STADIO i :	
final output torque	M_2 [Nm]	=	QUBO M_2 X STADIO i : x 98%	
final efficiency	η_d [%]	=	QUBO η_d x 98%	



QUBO + STADIO PERFORMANCE TABLES

P1 [kW]					i:	n ₂ (rpm)	M ₂ (Nm)	f _s
0,13	QUB0030	i:20	+ STADIO-63	+ 63A-4	59	23,9	34	0,8
	QUB0030	i:25	+ STADIO-63	+ 63A-4	73	19,1	40	0,8
	QUB0040	i:30	+ STADIO-63	+ 63A-4	88	15,9	49	1,3
	QUB0040	i:40	+ STADIO-63	+ 63A-4	117	11,9	60	1,0
	QUB0040	i:50	+ STADIO-63	+ 63A-4	147	9,6	70	0,7
	QUB0050	i:60	+ STADIO-63	+ 63A-4	176	8,0	83	1,2
	QUB0050	i:80	+ STADIO-63	+ 63A-4	234	6,0	100	1,0
QUB0050	i:100	+ STADIO-63	+ 63A-4	293	4,8	104	0,7	
0,18	QUB0040	i:30	+ STADIO-63	+ 63A-2	88	31,8	40	1,2
	QUB0040	i:40	+ STADIO-63	+ 63A-2	117	23,9	52	0,9
	QUB0040	i:20	+ STADIO-63	+ 63A-4	59	23,9	55	1,0
	QUB0040	i:25	+ STADIO-63	+ 63A-4	73	19,1	63	0,8
	QUB0040	i:30	+ STADIO-63	+ 63A-4	88	15,9	68	0,8
	QUB0050	i:60	+ STADIO-63	+ 63A-2	176	15,9	69	1,1
	QUB0050	i:80	+ STADIO-63	+ 63A-2	234	11,9	86	0,8
	QUB0050	i:40	+ STADIO-63	+ 63A-4	117	11,9	95	1,2
	QUB0050	i:50	+ STADIO-63	+ 63A-4	147	9,6	99	0,9
	QUB0050	i:60	+ STADIO-63	+ 63A-4	176	8,0	110	0,8
	QUB0063	i:80	+ STADIO-63	+ 63A-4	234	6,0	136	1,1
	QUB0063	i:100	+ STADIO-63	+ 63A-4	293	4,8	151	0,9
QUB0040	i:20	+ STADIO-71	+ 71A-6	59	15,3	84	0,8	
0,25	QUB0040	i:20	+ STADIO-71	+ 71A-4	59	23,8	78	0,8
	QUB0050	i:20	+ STADIO-71	+ 71A-4	59	23,8	79	1,4
	QUB0050	i:25	+ STADIO-71	+ 71A-4	74	19,0	92	1,1
	QUB0050	i:30	+ STADIO-71	+ 71A-4	88	15,9	104	1,2
	QUB0050	i:40	+ STADIO-71	+ 71A-4	118	11,9	134	0,9
	QUB0050	i:20	+ STADIO-71	+ 71B-6	59	15,3	122	1,0
	QUB0050	i:25	+ STADIO-71	+ 71B-6	74	12,2	143	0,8
	QUB0050	i:30	+ STADIO-71	+ 71B-6	88	10,2	162	0,9
	QUB0063	i:25	+ STADIO-71	+ 71A-4	74	19,0	98	1,2
	QUB0063	i:50	+ STADIO-71	+ 71A-4	147	9,5	165	1,2
	QUB0063	i:60	+ STADIO-71	+ 71A-4	176	7,9	190	1,0
	QUB0063	i:80	+ STADIO-71	+ 71A-4	235	6,0	227	0,8
	QUB0063	i:50	+ STADIO-71	+ 71B-6	147	6,1	258	0,9
	QUB0063	i:60	+ STADIO-71	+ 71B-6	176	5,1	296	0,8
	QUB0075	i:80	+ STADIO-71	+ 71A-4	235	6,0	232	1,2
	QUB0075	i:100	+ STADIO-71	+ 71A-4	294	4,8	277	1,0

P1 [kW]					i:	n ₂ (rpm)	M ₂ (Nm)	f _s
0,37	QUB0050	i:25	+ STADIO-71	+ 71A-2	88	38,1	68	1,0
	QUB0050	i:30	+ STADIO-71	+ 71A-2	73	31,7	99	1,1
	QUB0050	i:40	+ STADIO-71	+ 71A-2	118	23,8	99	0,8
	QUB0050	i:20	+ STADIO-71	+ 71B-4	59	23,8	116	0,9
	QUB0050	i:25	+ STADIO-71	+ 71B-4	73	19,0	136	0,8
	QUB0050	i:30	+ STADIO-71	+ 71B-4	88	15,9	154	0,8
	QUB0063	i:40	+ STADIO-71	+ 71B-4	118	11,9	205	1,1
	QUB0063	i:50	+ STADIO-71	+ 71B-4	147	9,5	245	0,8
	QUB0075	i:50	+ STADIO-71	+ 71B-4	147	9,5	257	1,2
	QUB0075	i:60	+ STADIO-71	+ 71B-4	176	7,9	285	1,0
	QUB0090	i:80	+ STADIO-71	+ 71B-4	235	6,0	357	1,1
	QUB0090	i:100	+ STADIO-71	+ 71B-4	294	4,8	429	0,9
	QUB0063	i:20	+ STADIO-80	+ 80A-6	60	15,0	188	1,2
	QUB0063	i:25	+ STADIO-80	+ 80A-6	75	12,0	230	1,0
	QUB0063	i:30	+ STADIO-80	+ 80A-6	90	10,0	252	1,0
	QUB0063	i:40	+ STADIO-80	+ 80A-6	120	7,5	326	0,8
	QUB0075	i:50	+ STADIO-80	+ 80A-6	150	6,0	389	0,9
QUB0075	i:60	+ STADIO-80	+ 80A-6	180	5,0	446	0,7	
0,55	QUB0050	i:20	+ STADIO-71	+ 71B-2	59	47,6	95	0,9
	QUB0050	i:30	+ STADIO-71	+ 71B-2	88	31,7	145	0,8
	QUB0063	i:40	+ STADIO-71	+ 71B-2	118	23,8	153	1,0
	QUB0063	i:50	+ STADIO-71	+ 71B-2	147	19,0	183	0,8
	QUB0063	i:20	+ STADIO-80	+ 80A-4	60	23,3	183	1,1
	QUB0063	i:25	+ STADIO-80	+ 80A-4	75	18,7	223	0,9
	QUB0063	i:30	+ STADIO-80	+ 80A-4	90	15,6	245	1,0
	QUB0063	i:20	+ STADIO-80	+ 80B-6	60	15,0	280	0,8
	QUB0075	i:40	+ STADIO-80	+ 80A-4	120	11,5	330	1,0
	QUB0075	i:50	+ STADIO-80	+ 80A-4	150	9,2	395	0,8
	QUB0075	i:30	+ STADIO-80	+ 80B-6	90	10,0	390	1,0
	QUB0075	i:40	+ STADIO-80	+ 80B-6	120	7,5	506	0,8
	QUB0090	i:80	+ STADIO-80	+ 80A-4	240	5,8	556	0,8
	QUB0090	i:50	+ STADIO-80	+ 80B-6	150	6,0	582	1,0
	QUB0090	i:60	+ STADIO-80	+ 80B-6	180	5,0	659	0,8
	QUB0110	i:80	+ STADIO-80	+ 80A-4	240	5,8	590	1,3
	QUB0110	i:100	+ STADIO-80	+ 80A-4	300	4,7	705	1,0
QUB0110	i:80	+ STADIO-80	+ 80B-6	240	3,8	906	1,0	
QUB0110	i:100	+ STADIO-80	+ 80B-6	300	3,0	1081	0,8	
0,75	QUB0063	i:20	+ STADIO-80	+ 80A-2	60	46,7	123	1,2
	QUB0063	i:25	+ STADIO-80	+ 80A-2	75	47,3	150	0,9
	QUB0063	i:30	+ STADIO-80	+ 80A-2	90	31,1	164	1,0
	QUB0063	i:20	+ STADIO-80	+ 80B-4	60	23,3	246	0,8
	QUB0075	i:25	+ STADIO-80	+ 80B-4	75	15,6	308	1,0
	QUB0075	i:30	+ STADIO-80	+ 80B-4	90	18,7	341	1,0
	QUB0075	i:40	+ STADIO-80	+ 80B-4	120	11,7	444	0,8
	QUB0090	i:80	+ STADIO-80	+ 80A-2	240	11,7	369	0,8
	QUB0090	i:50	+ STADIO-80	+ 80B-4	150	9,3	549	0,9
	QUB0090	i:60	+ STADIO-80	+ 80B-4	180	7,8	628	0,8
	QUB0110	i:80	+ STADIO-80	+ 80B-4	240	5,8	794	1,0
	QUB0110	i:100	+ STADIO-80	+ 80B-4	300	4,7	947	0,8
	QUB0075	i:30	+ STADIO-90	+ 90S-6	74	12,2	434	0,8
	QUB0090	i:30	+ STADIO-90	+ 90S-6	74	12,2	463	1,3
	QUB0090	i:40	+ STADIO-90	+ 90S-6	98	9,2	565	0,9
	QUB0110	i:60	+ STADIO-90	+ 90S-6	147	6,1	825	1,1

P1 [kW]					i:	n ₂ (rpm)	M ₂ (Nm)	f _s	
1,1	QUB0063	i:20	+ STADIO-80	+ 80B-2	60	46,7	180	0,8	
	QUB0075	i:25	+ STADIO-80	+ 80B-2	75	37,3	225	1,0	
	QUB0075	i:30	+ STADIO-80	+ 80B-2	90	31,1	250	1,0	
	QUB0090	i:40	+ STADIO-90	+ 90S-4	98	14,3	533	0,8	
	QUB0090	i:25	+ STADIO-90	+ 90L-6	61	14,7	585	0,8	
	QUB0090	i:30	+ STADIO-90	+ 90L-6	74	12,2	679	0,9	
	QUB0110	i:50	+ STADIO-90	+ 90S-4	123	11,4	662	1,2	
	QUB0110	i:60	+ STADIO-90	+ 90S-4	147	9,5	778	1,0	
	QUB0110	i:80	+ STADIO-90	+ 90S-4	196	7,1	951	0,7	
	QUB0110	i:40	+ STADIO-90	+ 90L-6	98	9,2	865	1,2	
	QUB0110	i:50	+ STADIO-90	+ 90L-6	123	7,3	1030	0,9	
	QUB0130	i:80	+ STADIO-90	+ 90S-4	196	7,1	936	1,1	
QUB0130	i:100	+ STADIO-90	+ 90S-4	245	5,7	1117	0,8		
1,5	QUB0090	i:25	+ STADIO-90	+ 90L-4	61	19,1	512	0,8	
	QUB0090	i:30	+ STADIO-90	+ 90L-4	74	22,9	595	0,9	
	QUB0110	i:60	+ STADIO-90	+ 90S-2	147	19,1	530	1,0	
	QUB0110	i:40	+ STADIO-90	+ 90L-4	98	14,3	758	1,1	
	QUB0110	i:50	+ STADIO-90	+ 90L-4	123	11,4	902	0,9	
	QUB0110	i:60	+ STADIO-90	+ 90L-4	147	9,5	1061	0,7	
	QUB0130	i:60	+ STADIO-90	+ 90L-4	147	9,5	1031	1,0	
	QUB0130	i:80	+ STADIO-90	+ 90L-4	196	7,1	1277	0,8	
	2,2	QUB0090	i:25	+ STADIO-90	+ 90L-2	61	45,7	376	0,8
		QUB0090	i:30	+ STADIO-90	+ 90L-2	74	38	436	0,9
		QUB0110	i:25	+ STADIO-90	+ 90L-2	61	45,7	377	1,6
		QUB0110	i:30	+ STADIO-90	+ 90L-2	74	38,1	437	1,5
QUB0110		i:40	+ STADIO-90	+ 90L-2	98	28,6	557	1,1	
QUB0110		i:50	+ STADIO-90	+ 90L-2	123	22,9	662	0,9	
QUB0110		i:25	+ STADIO-90	+ 90LB-4	61	22,9	754	1,1	
QUB0110		i:30	+ STADIO-90	+ 90LB-4	74	19,0	875	1,0	
QUB0110		i:40	+ STADIO-90	+ 90LB-4	98	14,3	1112	0,8	
QUB0130		i:25	+ STADIO-90	+ 90LB-4	61	22,9	729	1,5	
QUB0130		i:30	+ STADIO-90	+ 90LB-4	74	19,0	854	1,4	
QUB0130		i:40	+ STADIO-90	+ 90LB-4	98	24,3	1081	1,1	
QUB0130	i:50	+ STADIO-90	+ 90LB-4	123	11,4	1297	0,9		

DIMENSIONAL TABLES

QUBO + STADIO combinations

		STADIO-63		STADIO-71		STADIO-80		STADIO-90	
motor flange		63B5		71B5		80/90B5			
P		140		160		200			
QUBO flange		71B14		80B14		100B14			
P1		105		120		160			
output shaft diameter		D1	D2	D1	D2	D1	D2	D1	D2
i		11	14	14	19	19	24	24	28
		i:2,93	i:2,93	i:2,94	i:2,94	i:3	i:3	i:2,45	i:2,45
QUBO040	25								
	30								
	40								
	50								
	60								
QUBO050	80								
	100								
	25								
	30								
	40								
QUBO063	50								
	60								
	80								
	100								
	QUBO075	25							
30									
40									
50									
60									
QUBO090	80								
	100								
	25								
	30								
	40								
QUBO110	50								
	60								
	80								
	100								
	QUBO130	25							
30									
40									
50									
60									
80									
100									

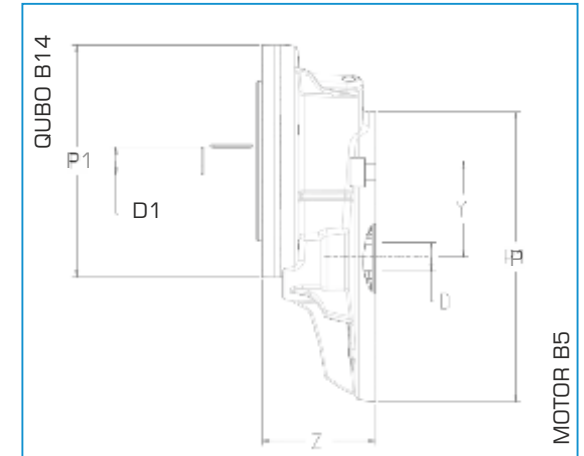

	input			output				
	motor flange	P	D	QUBO flange	P1	D1	Y	Z
STADIO-63	63B5	140	11	71B14	105	11(IEC63)	43	47
STADIO-71	71B5	160	14	80B14	120	14(IEC71)	54	55
STADIO-80	80B5	200	19	100B14(=71B5)	160	19(IEC80)	66	75
STADIO-90	90B5	200	24	100B14(=71B5)	160	24(IEC90)	66	75

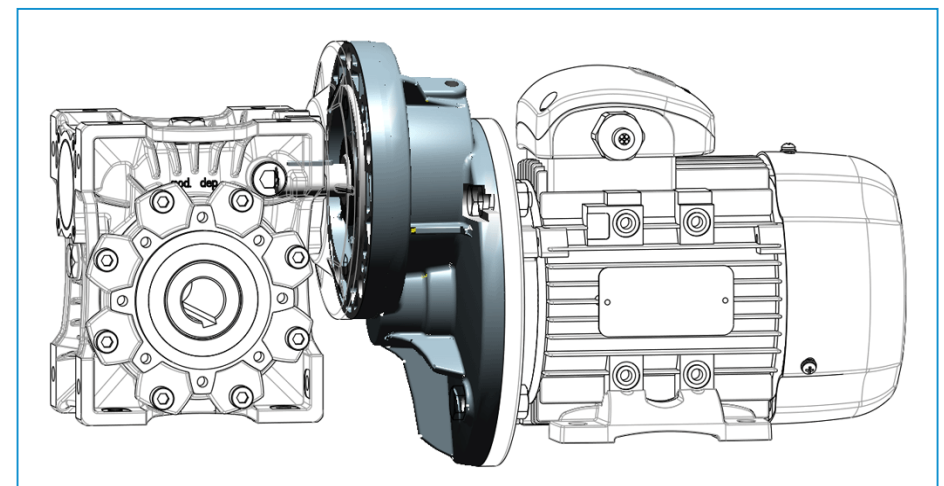

DIMENSIONAL TABLES

QUBO general data

QUBO type	A	C	G	H	I	K	KE	L	M	N(h8)	N1	O	P	Q	R	S	V	W	output			MB/MF						Kgs			
																			T	G1	D(H8)	B	D1(j6)	G2	G3	b1	t1		f		
QUBO030	54	81	55	40	30	44	M6x11(n°4)	56	65	55	29	6.5	75	44	57	5.5	27	-	20	63	14	5	16.3	20	9	56	45	3	10.5	M4	1.3
QUBO040	70	101	71	50	40	60	M6x10(n°4)	71	75	60	36.5	6.5	87	55	71.5	6.5	35	45°	23	78	18	6	20.8	30	14	69	53	5	16	M5	2.7
QUBO050	80	121	80	60	50	70	M8x10(n°4)	85	85	70	43.5	8.5	100	64	84	7	40	45°	30	92	25	8	28.3	30	14	82	64	5	16	M5	3.6
QUBO063	100	146	95	72	63	85	M8x14(n°8)	103	95	80	53	8.5	110	80	102	8	50	45°	40	112	25	8	28.3	40	19	95	75	6	21.5	M6	7.8
QUBO075	120	173	112.5	86	75	90	M8x14(n°8)	113	115	95	57	11	140	93	119	10	60	45°	50	120	28	8	31.3	50	24	107	90	8	27	M8	9
QUBO090	140	208	129.5	103	90	100	M10x18(n°8)	130	130	110	67	13	160	102	135	11	70	45°	50	140	35	10	38.3	50	24	126	108	8	27	M8	14
QUBO110	170	255	160	127.5	110	115	M10x18(n°8)	144	165	130	74	14	200	125	167.5	15	85	45°	60	155	42	12	45.3	60	28	156	135	8	31	M10	35
QUBO130	200	292.5	180	147.5	130	120	M12x21(n°8)	155	215	180	81	16	250	140	187.5	15.5	100	45°	60	170	45	14	48.3	80	30	172	155	8	33	M10	52
QUBO150	240	340	210	170	150	145	M12x21(n°8)	185	215	180	96	18	250	180	230	18	120	45°	72.5	200	50	14	53.8	-	-	-	-	-	-	-	91

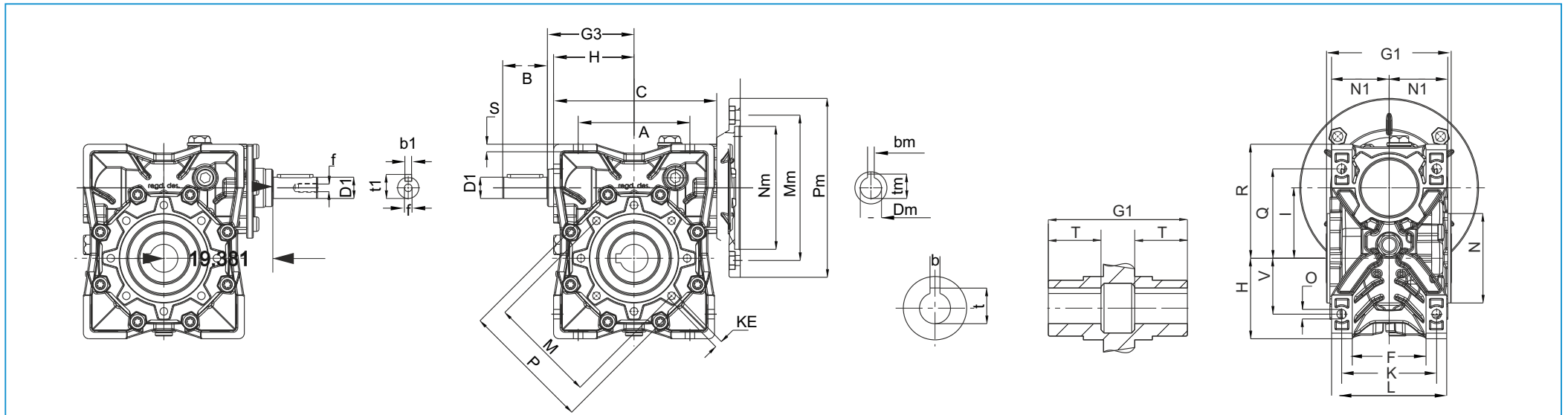

QUBO



QUBO+MF



QUBO+MB



QUBO+DEL

DIMENSIONAL TABLES

QUBO input and combinations

QUBO type	motor	type	Nm	Mm	Pm	Dm	Lm	tm	bm	7.5	10	15	20	25	30	40	50	60	80	100		
QUBO030	56	B14(*)	50	65	80	9	6	10.4	3													
		B5(*)	80	100	120	9	7	10.4	3													
	63	B5	95	115	140	11	8	12.8	4													
		B14	60	75	90		11.5															
QUBO040	63	B5	95	115	140	11	12	12.8	4													
		B14(*)	60	75	90	11	11															
	71	B5	110	130	160	14	10	16.3	5													
		B14(*)	70	85	105	14	6.5															
QUBO050	63	B5	95	115	140	11	12	12.8	4													
		B14(*)	70	85	105	14	8.5															
	71	B5	110	130	160	14	11	16.3	5													
		B14(*)	70	85	105	14	8															
80	B5	130	165	200	19	13	21.8	6														
	B14(*)	80	100	120	19	8																
QUBO063	71	B5	110	130	160	14	12	16.3	5													
		B14(*)	70	85	105	14	8															
	80	B5	130	165	200	19	13	21.8	6													
		B14(*)	80	100	120	19	7															
90	B5	130	165	200	24	13	27.3	8														
	B14(*)	95	115	140	24	11																
QUBO075	71	B5	110	130	160	14	12	16.2	5													
		B5	130	165	200	19	11			21.8	6											
	80	B14(*)	80	100	120	19	11	27.3	8													
		B5	130	165	200	24	11															
	90	B5	180	215	250	28	11	31.3	8													
		B14(*)	110	130	160	28	13															
112	B5	180	215	250	28	12																
QUBO090	80	B5	130	165	200	19	11	21.8	6													
		B5	180	215	250	28	13			31.3	8											
	90	B5	130	165	200	24	11	27.3	8													
		B14(*)	110	130	160	28	12															
QUBO110	100	B5	180	215	250	28	13	31.3	8													
		B5	110	130	160	28	12															
	112	B5	180	215	250	28	13	41.3	10													
		B5	230	265	300	38	16															
QUBO130	90	B5	130	165	200	24	12	27.3	8													
		B5	180	215	250	28	14			31.3	8											
	100/112	B5	230	265	300	38	16	41.3	10													
QUBO150	100/112	B5	180	215	250	28	14	31.3	8													
		B5	230	265	300	38	16			41.3	10											
	132	B5	250	300	350	42	16	45	12													

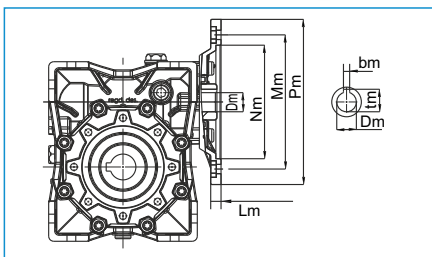

(*) Available as a special case. Check availability/lead times before ordering.

DIMENSIONAL TABLES

type	output flange F									output flange FL								
	KA	KB	KC	KM	KN (H8)	KO	KP	KQ	KW	KA	KB	KC	KM	KN	KO	KP	KQ	KW
QUB0030	54.5	6	4	68	50	6.5(n°4)	80	70	45°	-	-	-	-	-	-	-	-	-
QUB0040	67	7	4	75	60	9 (n°4)	110	95	45°	97	7	4	75	60	9 (n°4)	110	95	45°
QUB0050	90	9	5	85	70	11(n°4)	125	110	45°	120	9	5	85	70	11 (n°4)	125	110	45°
QUB0063	82	10	6	150	115	11(n°4)	180	142	45°	112	10	6	150	115	11 (n°4)	180	142	45°
QUB0075	111	13	6	165	130	14(n°4)	200	170	45°	-	-	-	-	-	-	-	-	-
QUB0090	111	13	6	175	152	14(n°4)	210	200	45°	-	-	-	-	-	-	-	-	-
QUB0110	131	15	6	230	170	14(n°8)	280	260	45°	-	-	-	-	-	-	-	-	-
QUB0130	140	15	6	255	180	16(n°8)	320	290	22.5°	-	-	-	-	-	-	-	-	-
QUB0150	155	15	6	255	180	16 (n°8)	320	290	22.5°	-	-	-	-	-	-	-	-	-



QUBO + F/FL

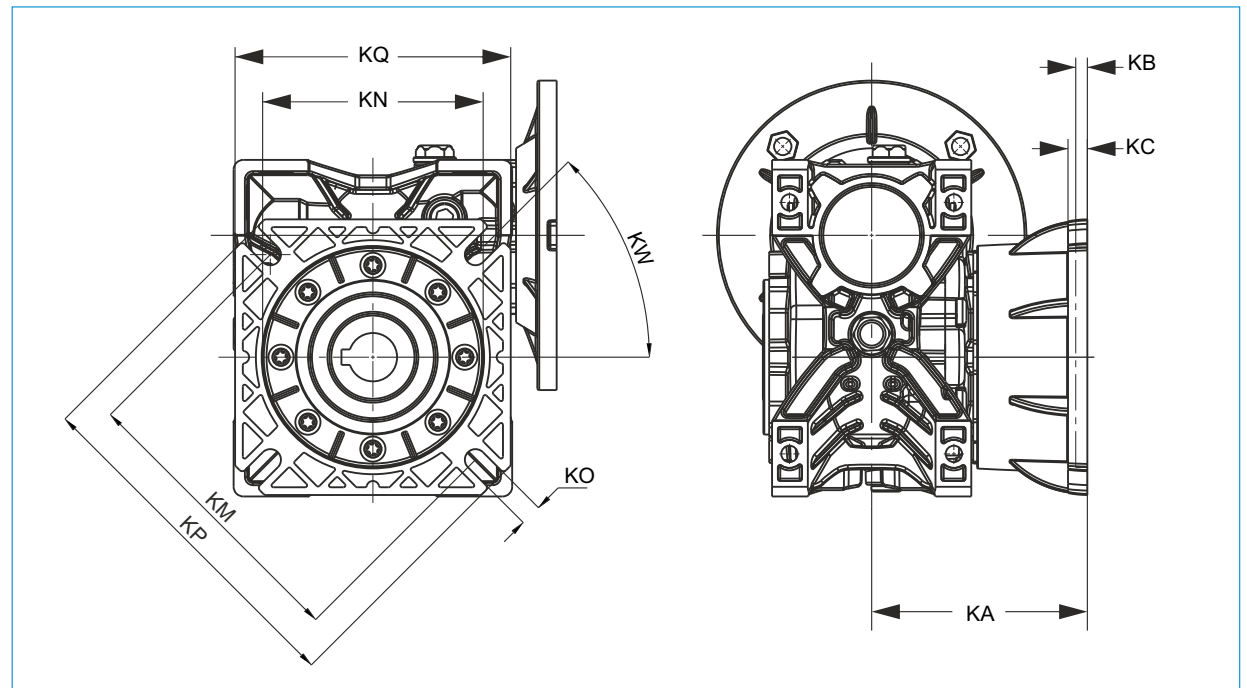

DIMENSIONAL TABLES

Accessories

Tipo	Torque arm				
	K1	G	KG	KH	R
QUB0030	85	14	24	8	15
QUB0040	100	14	31,5	10	18
QUB0050	100	14	38,5	10	18
QUB0063	150	14	49	10	18
QUB0075	200	25	47,5	20	30
QUB0090	200	25	57,5	20	30
QUB0110	250	30	62	25	35
QUB0130	250	30	69	25	35
QUB0150	250	30	84	25	35



QUBO + TA

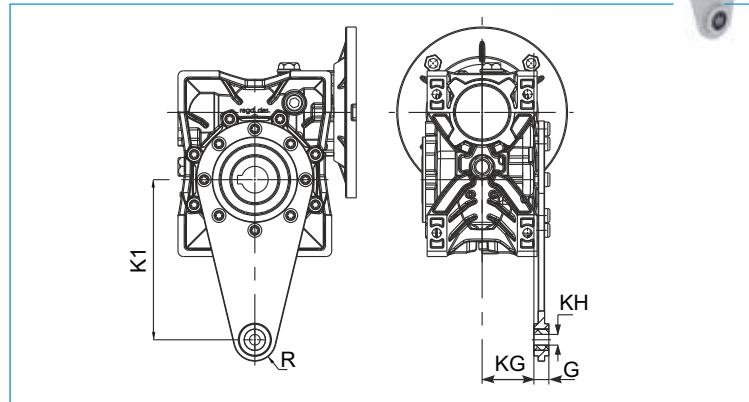

type	d (h6)	Single and double output shaft								
		B	B1	G1	H	L1	f	b1	t1	
QUB0030	14	30	32,5	63	8	128	M5	5	16	
QUB0040	18	40	43	78	9	164	M6	6	20,5	
QUB0050	25	50	53,5	92	13	199	M8	8	28	
QUB0063	25	50	53,5	112	13	219	M8	8	28	
QUB0075	28	60	63,5	120	15	247	M10	8	31	
QUB0090	35	80	84	140	15	308	M12	10	38	
QUB0110	42	80	84,5	155	15	324	M16	12	45	
QUB0130	45	80	85	170	15	340	M16	14	48,5	
QUB0150	50	82	87	200	15	374	M16	14	53,5	

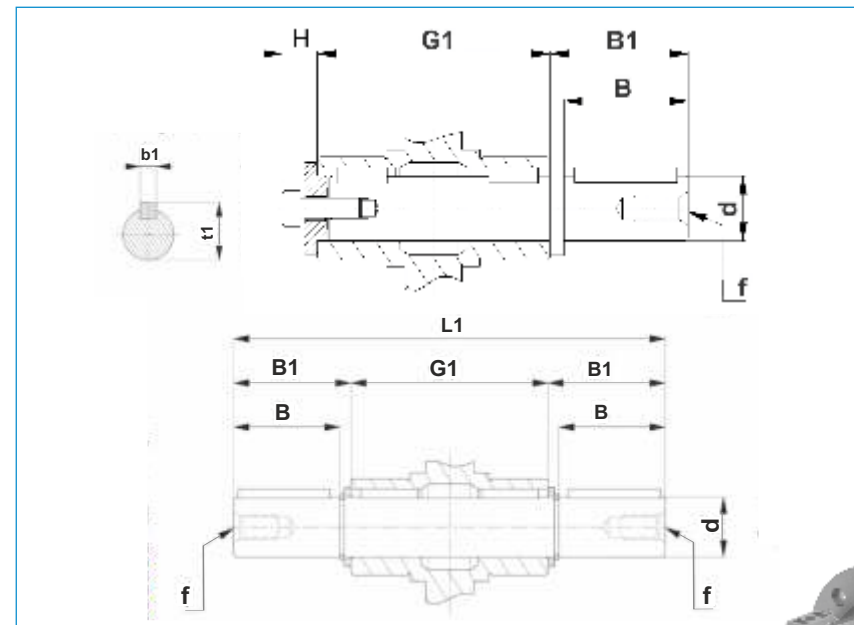

Combined

QUBO + QUBO	K	I1	I2	G4
QUBO 030+QUBO 040	120	30	10	198
QUBO 030+QUBO 050	130	30	20	218
QUBO 030+QUBO 063	145	30	33	245
QUBO 040+QUBO 075	164,5	40	35	286
QUBO 040+QUBO 090	182,5	40	50	321
QUBO 050+QUBO 110	227,5	50	60	397,5
QUBO 063+QUBO 130	256	63	67	455

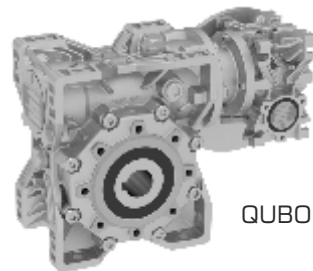
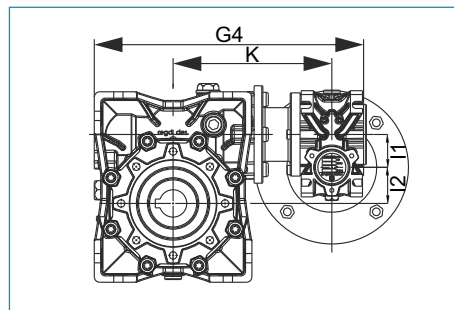

QUBO + QUBO

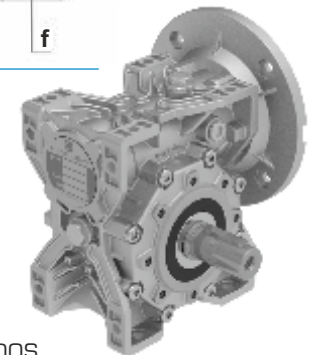

QUBO + SOS/DOS

COMPONENTS LIST

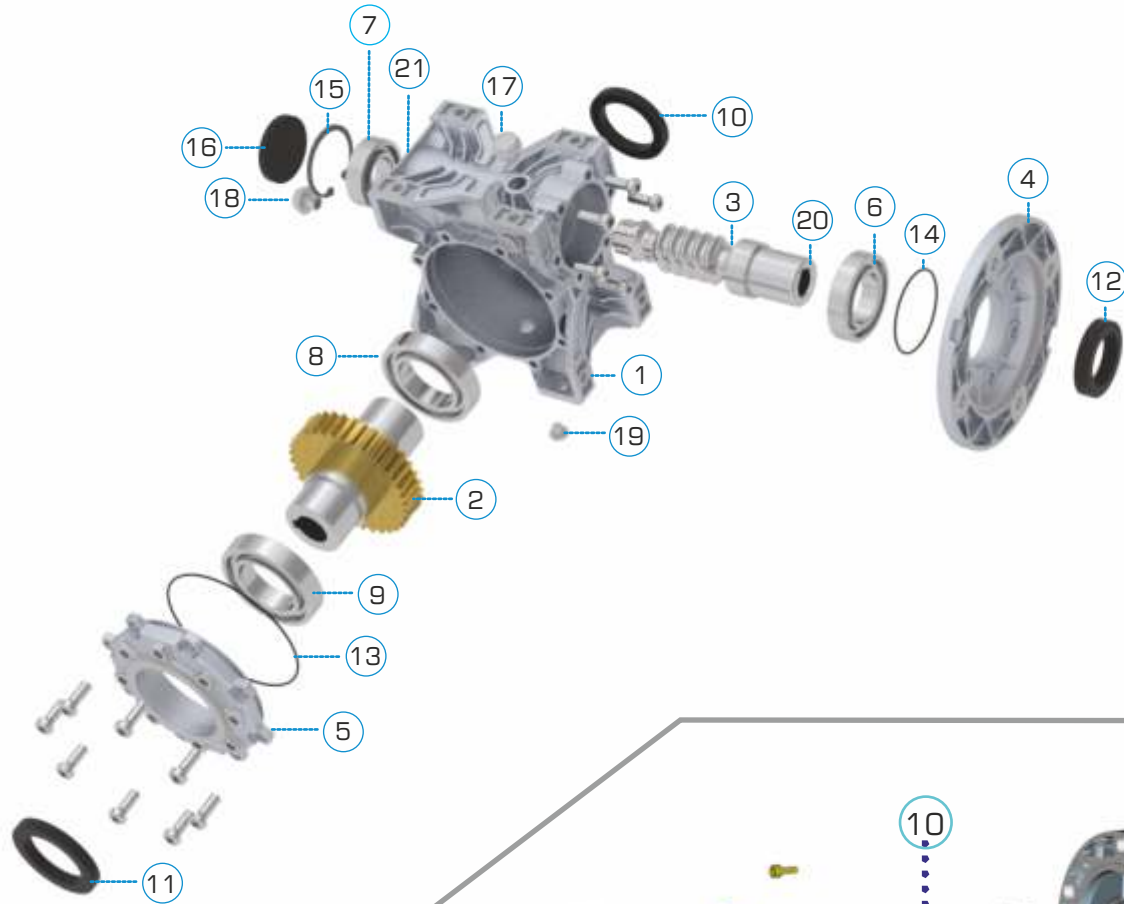

	BEARINGS				OIL SEALS		
	6	7	8	9	10	11	12
QUB0030	61904	6002-2RS	6005	6005	25x47x7	25x47x7	20x30x7
QUB0040	6005	6203-2RS	6006	6006	30x40x7	30x40x7	25x35x7
QUB0050	6006	6204-2RS	6008-2RS	6008-2RS	40x62x8	40x62x8	30x47x7
QUB0063	6007	6205-2RS	6009-2RS	6009-2RS	45x65x8	45x65x8	35x52x10
QUB0075	32008-RS	30206-RS	6010-2RS	6010-2RS	50x72x8	50x72x8	40x60x10
QUB0090	32008-RS	30206-RS	6012-2RS	6012-2RS	60x85x10	60x85x10	40x60x10
QUB0110	32010-RS	32207-RS	6013-2RS	6013-2RS	60x85x8	60x85x10	50x68x8
QUB0130	32010-RS	32207-RS	6014-2RS	6014-2RS	70x90x10	70x90x10	50x68x8
QUB0150	30212-RS	30209-RS	6018-2RS	6018-2RS	90x120x12	90x120x12	60x90x10

N°	CODE	N°	CODE	N°	CODE
1	QUBOHOU	8	QUBOB08	15	QUBOSEE
2	QUBOGEA	9	QUBOB09	16	QUBOCOV
3	QUBOSHA	10	QUBOS10	17	QUBOBPL
4	QUBOFLA	11	QUBOS11	18	QUBO LPL
5	QUBOCAP	12	QUBOS12	19	QUBOFPL
6	QUBOB06	13	QUBOS13	20	QUBON20
7	QUBOB07	14	QUBOS14	21	QUBON21

N°	CODE
1	BEA...
2	BEA...
3	BEA...
4	OS...
5	OS...
6	STAHOU
7	STAB14
8	STAPIN
9	STAGEA
10	STASHA
11	STAS11

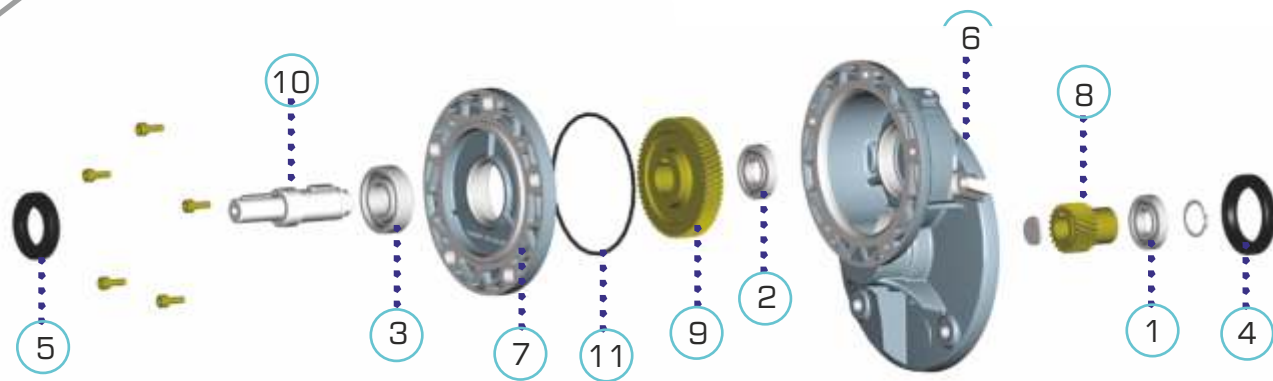

	part nr	STADIO-63		STADIO-71		STADIO-80		STADIO-90			
		BEA	OS	BEA	OS	BEA	OS	BEA	OS		
input	bearing	1	4	16004	19x42x6	6005	24x47x6	6206	30x62x7	6007	35x62x7
output	bearing	2	5	16003	17x30x7	16004	20x35x7	6006	30x47x7	6006	30x47x7
	oil seal	3	5	6002	17x30x7	6003	20x35x7	6006	30x47x7	6006	30x47x7



CMM for Mechanical Inspection



Gear Lead & Profile Tester

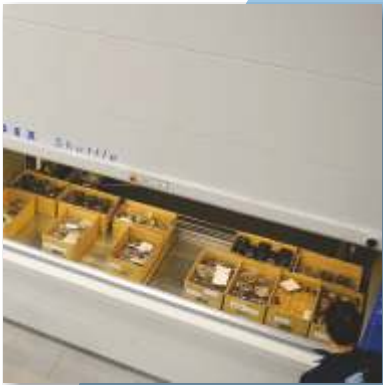

KARDEX for Gear Storage



Gear Profile Grinding



Magnifying Glass to Check Gear



Gearbox Machining

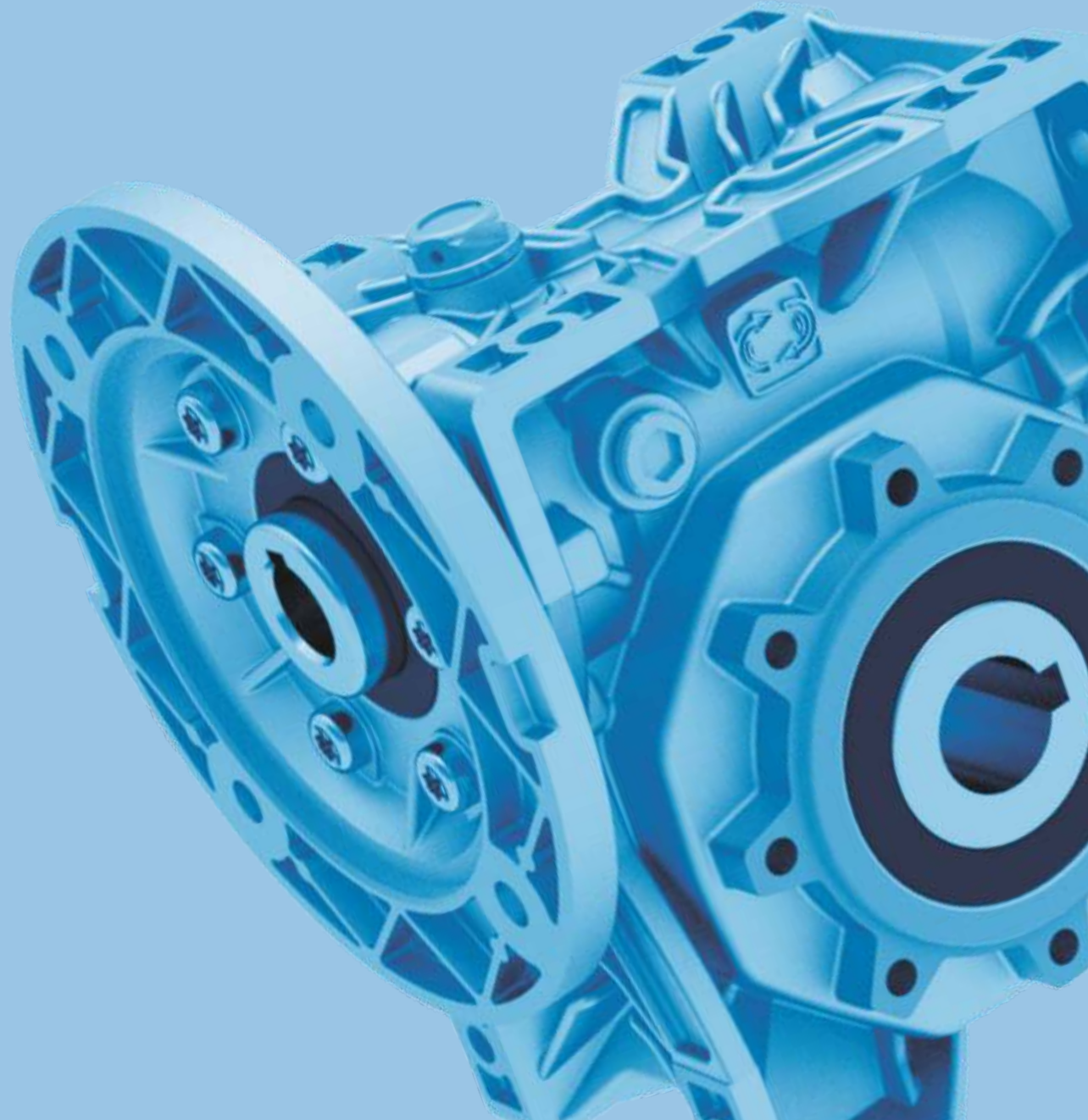

All information and data presented in this catalogue have been checked with greatest care. We however do not assume responsible for any unintended errors and omissions. Our designs are being continuously improved, so please reconfirm specifications and dimensions prior to ordering.

Regional Sales Offices:

Rotomotive Ahmedabad

Rotomotive Powerdrives India Ltd.
Regional Office: Shridhar Bunglows
No.14, Nr. Mansarover Tenament
Nr. Arpan School, Nirang Cross Rd.
PO. Vastral, Ahmedabad - 382 418
Tel/Fax No: +91-79-29093837
Cell No.: +91 93746 31145
E-mail: sales.ahd@rotomotive.com

Rotomotive Delhi

305, 3rd Floor, Nipun Tower,
Plot no. 15, Karkardooma Community Center,
Delhi - 110092
Tel No. : 011447007139
Cell No. : 93123 54230
Email : sales.delhi@rotomotive.com

Rotomotive Mumbai

Rotomotive Powerdrives India Ltd.
303 Swastik Disa Corporate Park,
Lal Bahadur Shastri Marg,
Opposite Shreyas Cinema,
Ghatkopar (W), Mumbai - 400086
Cell No.: +91 90237 27849
E-mail: sales.mum@rotomotive.com

Rotomotive Secunderabad

Rotomotive Powerdrives India Ltd.
No 6013, VI Floor, Emerald House
S.D. Road, Secunderabad - 500 003
Cell No.: 093466 16807
E-mail: sales.sec@rotomotive.com

Rotomotive Bangalore

Rotomotive Powerdrives India Ltd.
Asha Chambers, F15, #2 (Old # 33)
Venkataswamy Raju road, Kumarapark West
Bangalore - 560020
Tel:+91- 80 - 23465240/23465241
Fax: +91 - 80 - 4147 9547
Cell No.: +91 93437 04949 / 93421 61610
E-mail: sales.blr@rotomotive.com

Rotomotive Pune

Rotomotive Powerdrives India Ltd.
Plot No 425/77, T.M.V Colony,
Opposite Katariya High School
Gultekdi, Pune - 411037
Cell No.: +91 87888 32719 / 90288 60832
E-mail: sales.pune@rotomotive.com



Rotomotive Powerdrives India Ltd.

223, Napa Talpad, Gana-Borsad Road,
Tal: Borsad, Anand, Gujarat - 388 560, INDIA.
Ph.: +91 - 9227110030
Fax: +91 - 2692 - 235209
E-mail: info@rotomotive.com
Website: www.rotomotive.com

Authorised Dealer