

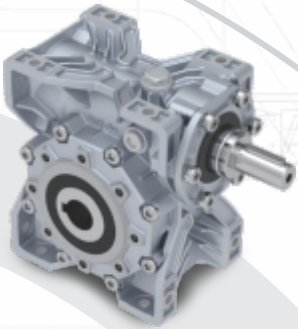

rotomotive

looks good. performs better.



QUBO Series
High Performance
Worm Gearboxes



ROBUS Series
Helical Gearboxes

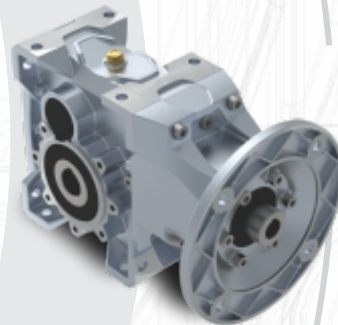

BEVOX Series
Heli-Bevel Gearboxes

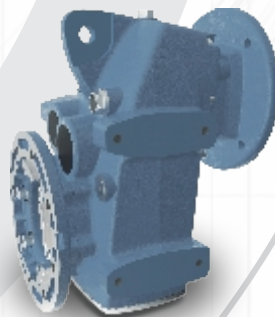

STON Series
Parallel Shaft
Helical Gearboxes

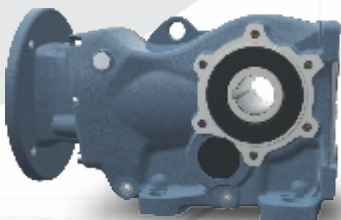

ENDURO Series
Bevel Helical Gearboxes

QUBO Series | High Performance Worm Gearboxes

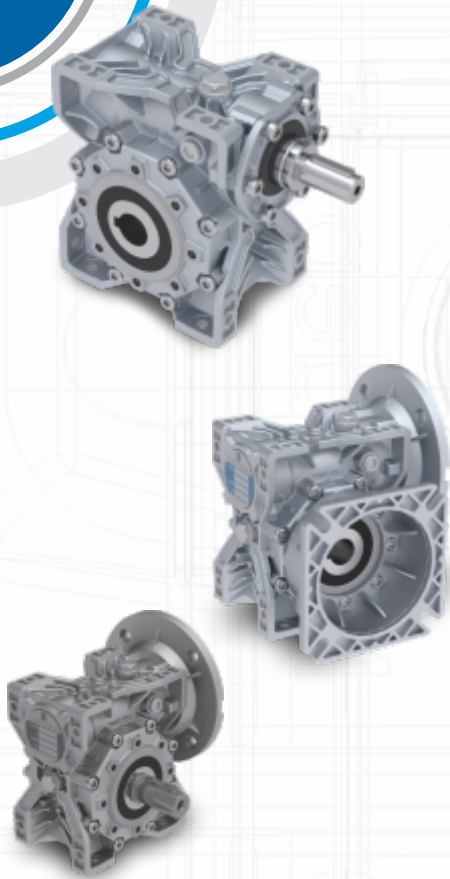

- Taper roller bearings to withstand axial thrust
- Patented die-cast Aluminium housing (upto Box 90)
- Super-finished gears for low noise
- Synthetic lubrication
- Anti corrosion coating
- Breather plugs for cooler running
- Ribbed construction for high strength
- Assembled in a world class plant in India
- IEC Input flanges & Solid input shaft option
- Output flange and solid out put shaft option

QUBO – SELECTION GUIDE KW / SIZE / RATIO

input PAM	56		63		71		80		90		100 / 112		132		160		
	9 mm		11 mm		14 mm		19 mm		24 mm		28 mm		38 mm		42 mm		
Pn1 kW	0.06	0.09	0.12	0.18	0.25	0.37	0.55	0.75	1.1	1.5	2.2	3.7	5.5	7.5	11	15	
Pn1 HP	0.09	0.18	0.18	0.25	0.35	0.5	0.75	1	1.5	2	3	5	7.5	10	15	20	
input n ₁ = 1440 RPM	100				63	75	90	110	110	130	150						100
	80					63	75	90	110	130	150						80
	60						63	75	90	110	130	150					60
	50			40		50		63	75	90	110	130	150				50
	40							63	75	90	110	130	150				40
	30				40				63	75	90	110	130	150			30
	25	30	30							75	90	110	130	150			25
	20										75	90	110	130	150		20
	15											75	90	110	130	150	15
	10												75	90	110	130	10
7.5													75	90	110	7.5	

ROBUS Series | Helical Gearboxes



- Unicase cast iron body for extreme rigidity
- All gears hardened and ground to DIN Class 6
- Top opening for easy maintenance
- Diecast Aluminium cover
- Multiple input and output flange options
- Oversized bearings for dual support on all gears
- Synthetic lubrication

SELECTION GUIDE KW / SIZE / RATIO

input PAM	63		71		80		90		100/112		132		160		180		
	11 mm		14 mm		19 mm		24 mm		28 mm		38 mm		42 mm		48 mm		
P _{n1} kW	0.12	0.18	0.25	0.37	0.55	0.75	1.1	1.5	2.2	3	3.7	5.5	7.5	11	15	18.5	22
P _{n1} Hp	0.18	0.25	0.35	0.5	0.75	1	1.5	2	3	4	5	7.5	10	15	20	25	30
input n ₁ = 1440 RPM	120																120
	110																110
	100																100
	90																90
	80																80
	70																70
	60																60
	55																55
	50																50
	45																45
Robus ratio i:	40	12	12	12													40
	35																35
	30																30
	25																25
	20																20
	15																15
	10																10
	5																5

= 3 stages
 = 2 stages

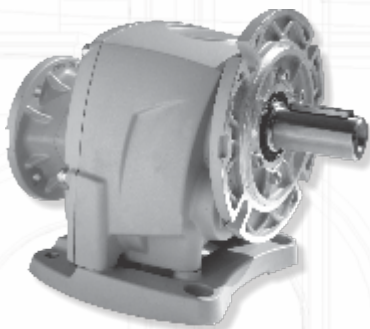

BEVOX Series | Heli-Bevel Gearboxes



- Housing and input flanges are in aluminium pressure die cast
- Hypoid gear in first stage (2 stages) and middle stage (3 stages).
- Gears are of case hardened steel & profile ground – improve efficiency and durability, reduce noise
- Side cover for easy maintenance
- IEC input flange & Hollow output shaft
- Optional solid output shaft & output flange
- Torque capacity : 130 Nm to 500 Nm
- Reduction ratio : 5 to 300 (2 & 3 stages)
- Synthetic Lubrication - ISO VG320 grade
- Same foot print of equivalent QUBO size, easy one to one replacement

STON Series | Parallel Shaft Helical Gearboxes

- Housing and Output flange material are in cast Iron
- Side cover for easy maintenance
- Dual bearing support at input shaft
- Synthetic oil - ISO VG220 grade
- IEC input flange & Hollow output shaft
- Optional solid output shaft, output flange & torque arm
- Hold-back available as optional accessories
- Torque capacity : 200 Nm to 4300 Nm
- Reduction ratio : 4 to 120

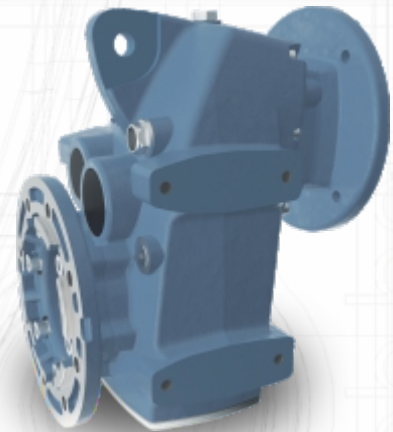

ENDURO Series | Bevel Helical Gearboxes

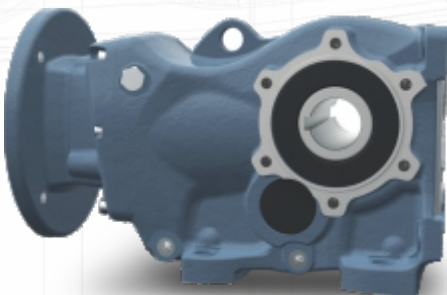

- 90° angle power transmission
- Housing and Output flange material are in cast Iron
- Side cover for easy maintenance
- Dual bearing support at input shaft
- Synthetic oil - ISO VG220 grade
- IEC input flange & Hollow output shaft
- Optional solid output shaft, output flange & torque arm
- Hold-back available as optional accessories
- Torque capacity : 200 Nm to 4300 Nm
- Reduction ratio : 4 to 120



Plant in Italy



Plant in India



Authorised Dealer



Rotomotive Powerdrives India Ltd.

223, Napa Talpad, Gana-Borsad Road, Tal: Borsad, Anand-388560, Gujarat, India

Ph.: +91-9227110010/20/30 Fax: +91-2692-235209 Email: info@rotomotive.com • www.rotomotive.com